



BU 0155 – en

## NORDAC LINK (SK 155E-FDS / SK 175E-FDS)

Users Manual for Motor Starters as Field Distributors





## Read document and keep for future reference

Read this document carefully prior to performing any work on or putting the device into operation. It is essential to read and observe the instructions in this document. They serve as the prerequisite for smooth and safe operation and the fulfilment of any warranty claims.

Contact Getriebebau NORD GmbH & Co. KG if your questions regarding the handling of the device are not answered in this document or if you require further information.

The German version of this document is the original. The German document is always decisive. If this document is available in other languages, this will be a translation of the original document.

Keep this document in the vicinity of the device so that it is available if required.

Use the version of this documentation that is valid for your device at the time of delivery. You can find the currently valid version of the documentation under [www.nord.com](http://www.nord.com).

Please also note the following documents:

- Catalogue “NORDAC electronic drive technology” ([E3000](#)),
- Documentation for optional accessories
- Documentation for equipment which is attached or provided.

Please contact [Getriebebau NORD GmbH & Co. KG](#) if you require further information.

## Documentation

<b>Title:</b>	<b>BU 0155</b>	
<b>Order no.:</b>	<b>6071502</b>	
<b>Series:</b>	SK 1x5E-FDS	
<b>Device series:</b>	SK 155E-FDS, SK 175E-FDS	
<b>Device types:</b>	SK 1x5E-FDS-111-340-xxx SK 1x5E-FDS-301-340-xxx	0.06 – 3.0 kW, 3~ 380-500 V

## Version list

Title, Date	Order number	Software version of device	Remarks
<b>BU 0155</b> , September 2016	<b>6071502/ 3916</b>	V 1.0 R0	First edition for pilot series devices (field test).
<b>BU 0155</b> , July 2017	<b>6071502/ 2817</b>	V 1.0 R2	<ul style="list-style-type: none"> <li>• Names of option slots for control elements changed to H1, H2 and H3</li> <li>• Power connection plug and M12 plug connector: Correction of various pin connections</li> <li>• Parameter P434, function 21 added</li> <li>• Parameters P203, P570: Value range changed</li> <li>• Potentiometers P1 and P2: Setting values changed</li> <li>• DIP switch S1: Setting values changed</li> <li>• CE Declaration of Conformity added</li> <li>• Various other corrections</li> </ul>
<b>BU 0155</b> , April 2018	<b>6071502/ 1618</b>	V 1.0 R2	For instance <ul style="list-style-type: none"> <li>• General corrections</li> <li>• Adaptation of safety information</li> <li>• Revision of warnings and hazard notes</li> <li>• Inclusion of UL data</li> <li>• AS-Interface supplement "AXS" single slave</li> <li>• Connection accessories added</li> <li>• Update of EU Declaration of Conformity</li> </ul>
<b>BU 0155</b> , September 2020	<b>6071502/ 3520</b>	V 1.2 R0	For instance <ul style="list-style-type: none"> <li>• General corrections</li> <li>• Size 0 added</li> <li>• Parameter P130 enhanced by combined mode</li> <li>• Parameter P539 enhanced</li> <li>• New parameter P780</li> <li>• Chapters "Motor cables", "Mains cables" and "Daisy chain cables" added</li> </ul>
<b>BU 0155</b> , July 2022	<b>6071502/ 2722</b>	V 1.2 R1	For instance <ul style="list-style-type: none"> <li>• General corrections</li> <li>• Further supplements to size 0</li> <li>• Description name plate expanded</li> <li>• Description adhesive label revised</li> </ul>

**Table 1: Version list**

## Copyright notice

As an integral component of the device described here, this document must be provided to all users in a suitable form.

Any editing or amendment or other utilisation of the document is prohibited.

## Publisher

### **Getriebebau NORD GmbH & Co. KG**

Getriebebau-Nord-Straße 1 • 22941 Bargteheide, Germany • <http://www.nord.com>

Fon +49 (0) 45 32 / 289-0 • Fax +49 (0) 45 32 / 289-2253

**Member of the NORD DRIVESYSTEMS Group**



## Table of Contents

<b>1</b>	<b>General</b> .....	<b>10</b>
1.1	Overview .....	11
1.2	Delivery .....	12
1.3	Scope of delivery.....	13
1.4	Presentation conventions.....	14
1.4.1	Warning information .....	14
1.4.2	Other information.....	14
1.5	Safety, installation and application information .....	14
1.6	Warning and hazard information .....	19
1.6.1	Warning and hazard information on the product.....	19
1.7	Standards and approvals .....	20
1.7.1	UL and CSA approval.....	20
1.8	Type code / nomenclature.....	23
1.8.1	Type plate.....	23
1.8.2	Plates with additional information .....	23
1.8.2.1	Warning information .....	23
1.8.2.2	Information regarding the power plug connectors .....	23
1.8.3	Field Distribution System type code .....	26
1.9	Version with protection class IP65 .....	26
<b>2</b>	<b>Assembly and installation</b> .....	<b>27</b>
2.1	Installation.....	28
2.2	Option slots and equipment versions .....	29
2.2.1	Option slots.....	29
2.2.1.1	Connection level .....	29
2.2.1.2	Control level .....	30
2.2.1.3	Maintenance switch level .....	30
2.2.2	Configuration versions .....	31
2.2.2.1	Configurable options .....	31
2.2.2.2	Configuration of option slots of the control level .....	32
2.2.2.3	Configuration of option slots on the connection level .....	36
2.2.2.4	Configuration of the option slot for the maintenance switch level .....	38
2.3	Electrical Connection .....	39
2.3.1	Wiring guidelines .....	39
2.3.2	Electrical connection of power unit .....	41
2.3.2.1	Mains connection .....	41
2.3.2.2	Motor cable (U, V, W, PE) .....	42
2.3.2.3	Electromechanical brake .....	42
2.3.3	Electrical connection of the control unit .....	43
2.3.3.1	Control connection details .....	45
<b>3</b>	<b>Display, operation and options</b> .....	<b>47</b>
3.1	Displays .....	48
3.2	Control and parametrisation options .....	49
<b>4</b>	<b>Commissioning</b> .....	<b>50</b>
4.1	Factory settings.....	50
4.2	Starting up the device .....	51
4.2.1	Connection .....	52
4.2.2	Configuration .....	52
4.2.2.1	Parameterisation .....	53
4.2.2.2	Potentiometers P1 to P3 .....	54
4.2.2.3	DIP switch (S1, S2) .....	55
4.2.2.4	Overview of disconnection modes .....	56
4.3	AS Interface (AS-i) .....	58
4.3.1	The bus system .....	58
4.3.2	Features and technical data .....	59
4.3.3	Bus structure and topology .....	60
4.3.4	Commissioning.....	62
4.3.4.1	Connection .....	62
4.3.4.2	Displays .....	62

4.3.4.3	Configuration	63
4.3.4.4	Addressing	65
4.3.5	Certificate .....	66
4.4	PROFIBUS DP .....	67
4.4.1	The bus system .....	67
4.4.2	Features .....	67
4.4.3	Commissioning .....	68
4.4.3.1	Connection	68
4.4.3.2	Displays	68
4.4.3.3	Configuration	68
4.4.3.4	Addressing	70
<b>5</b>	<b>Parameter</b> .....	<b>71</b>
5.1	Parameter overview .....	73
5.2	Description of parameters .....	74
5.2.1	Explanation of parameter description .....	74
5.2.2	Operating displays .....	75
5.2.3	Basic parameters .....	76
5.2.4	Motor data .....	78
5.2.5	Speed control .....	79
5.2.6	Control terminals .....	80
5.2.7	Additional parameters .....	84
5.2.8	Information .....	88
<b>6</b>	<b>Operating status messages</b> .....	<b>93</b>
6.1	Display of messages .....	93
6.2	Diagnostic LEDs on device .....	94
6.3	Messages .....	95
6.4	FAQ operational problems .....	98
<b>7</b>	<b>Technical data</b> .....	<b>99</b>
7.1	General motor starter data .....	99
7.2	Electrical data .....	100
7.2.1	Electrical data .....	100
<b>8</b>	<b>Additional information</b> .....	<b>101</b>
8.1	Electromagnetic compatibility (EMC) .....	101
8.1.1	General Provisions .....	101
8.1.2	EMC evaluation - EN 55011-1 (environmental standard) .....	102
8.1.3	EMC of device .....	103
8.1.4	EU Declaration of Conformity .....	104
8.2	Operation on the FI circuit breaker .....	105
8.3	Trigger classes (I <sup>2</sup> t) .....	105
8.4	Switch-on cycle .....	106
8.5	Connection accessories .....	107
8.5.1	Power connections - mating connectors .....	107
8.5.2	M12 Y distributor .....	108
8.5.3	Motor cable .....	108
8.5.4	Low voltage cable .....	109
8.5.5	Daisy chain cable .....	109
<b>9</b>	<b>Maintenance and servicing information</b> .....	<b>110</b>
9.1	Maintenance Instructions .....	110
9.2	Service notes .....	111
9.3	Abbreviations .....	112

## List of illustrations

Figure 1: Trigger class curves .....	105
Figure 2: Trigger times for warm operating state (with previous: I = continuous $I_{nenn}$ ) .....	106

## List of tables

Table 1: Version list .....	3
Table 2: Warning and hazard information on the product.....	19
Table 3: Standards and approvals.....	20
Table 4: Configuration – Comparison of hardware and software adjustments .....	52
Table 5: Parameters and functions depending on P130.....	53
Table 6: FAQ operational problems.....	98
Table 7: EMC - Limit class in accordance with EN 55011 .....	102
Table 8: Overview according to product standard EN 60947-4-2 .....	103

## 1 General

A two-phase phase section enables both motor start and soft start. The phase section procedure is chosen so that the resulting alternating torques are kept as low as possible. A comprehensive spectrum of monitoring functions rounds off the portfolio.

Thanks to the versatile setting options, all three-phase asynchronous motors can be operated.

The motor starter is principally designed for a three-phase mains connection. The power range is from 0.06 kW to 3.0 kW.

The device series can be adapted to individual requirements by means of modular assemblies.

This manual is based on the device software as stated in the version list (see P707). If the motor starter uses a different software version, this may cause differences. If necessary, the current manual can be downloaded from the internet (<http://www.nord.com/>).

Additional descriptions exist for optional functions and bus systems (<http://www.nord.com/>).



### Information

#### Accessories

The accessories listed in the manual are also subject to changes. Current details of these are included in separate data sheets, which you can find under <http://www.nord.com/> under the heading Documentation → Manuals → Electronic drive technology → Find technical information/data sheet. The data sheets available at the date of publication of this manual are listed by name in the relevant sections (TI ...).

---

The device series' various versions result in differences between the functionalities (e.g. with integrated AS-Interface or integrated PROFIBUS DP bus interface).

The simplest configuration allows for the setting of all important parameters using up to four potentiometers and four DIP switches without a PC or control device. LEDs are available for diagnosing the operating states. The use of a control module is therefore not mandatory.

A typical feature of this frequency inverter series is their installation close to the motor, e.g. on the wall or on a machine frame.

All electrical connections (power connections and control connections) are made with plug connectors. This considerably simplifies the installation of the frequency inverter and opening the FI is not necessary.

In order to obtain access to all parameters, the internal RS232 interface (access via RJ12 connection) can be used. Access to the parameters is made e.g. via an optional SimpleBox or ParameterBox.

The parameter settings modified by the owner/operator must be saved in the Flash memory of the device (**P550**). Otherwise the changed parameter settings would be lost when the device was switched off.

The device is configured according to the customer's individual requirements. The device equipment is therefore realised ex works. Later retrofittings of options or device conversions are not planned.

## Information

### The device must not be opened.

The device must not be opened at any time during its service life and does not need to be. All mounting, installation and commissioning works are only done on the closed device.

- Assembly is done via freely accessible mounting holes.
- Electrical connection is exclusively established via plug connectors.
- Operational settings are made via parameter adjustments or via DIP switches and potentiometers. The access to these elements or for the connection of a parameterisation tool is via blind plugs. These blind plugs may only be removed for works in connection with commissioning and must be properly replaced afterwards.
- Diagnostic LEDs for displaying switching and operating states are externally visible.

## 1.1 Overview

This manual describes the total number of possible functions and configurations. Depending on the device type, the configuration and functions are limited. Devices of type SK 175E-FDS have the maximum configuration for the integrated additional characteristics.

### Basic characteristics

- Close-to-motor mounting as wall mounting
- 5 digital inputs <sup>a), b)</sup>
- 2 digital outputs <sup>b)</sup>
- Separate temperature sensor input (TF+/TF-)<sup>b)</sup>
- Motor overload protection (I<sup>2</sup>t triggering characteristic according to EN 60947) → No motor protection switch required but only one backup fuse!
- Mains and motor failure monitoring
- Magnetisation monitoring (minimum current monitoring)
- Automatic phase sequence detection
- Soft start
- Permissible ambient temperature -25°C to 50°C (pay attention to technical data)
- Integrated EMC mains filter for Class A limit values
- 2 x DIP switch and 3 x potentiometer for configuration
- LEDs for diagnosis (including signal statuses DIs/DOs)
- RS232-/RS485 interface via RJ12 plug connector, alternatively USB (only RS232)
- 24 V DC control voltage
  - Must be provided via a plug connector, or
  - can be provided by the device (only with option -HVS).It is also possible to connect an external 24 V DC voltage supply via optional plug connectors in order to supply a high-power peripheral (e.g. actuators).
- Integrated PLC ( [BU 0550](#))

a) If necessary, individual inputs may be defined at the factory by using certain optional modules.

b) Connection is only possible via optional plug connectors.

### Additional characteristics

The devices are available in the *-AS-i*, *-AUX*, *-AXS* or *-ASS* versions with integrated *AS-Interface* or *-PBR* with integrated *PROFIBUS DP*.

The differences between the individual versions (SK 155E-FDS / SK 175E-FDS) are summarised in the following table and described in this manual.

Characteristic	155E-Axx <sup>a)</sup>	155E-PBR	175E-Axx <sup>a)</sup>	175E-PBR
Reversing function			x	x
AS-Interface (4I/4O)	AS-i		AS-i	
PROFIBUS DP (4I/4O)		PBR		PBR

a) AS-i, -AUX, -AXS, -ASS

## Optional features

The FI can be individually adapted to the drive task. For this, a comprehensive selection of interfaces, plug connections and control elements are available, which can be used during the manufacture of the FI according to the customer's requirements.

Depending on the configuration, the meaning of the individual LEDs, function or assignment of individual plug connectors or the function of control elements (e.g. switches) may differ. The possible combinations will be illustrated and explained in the course of this manual. The individual configuration of the FI can be identified using the type plate and can be compared with the details in the manual.

## 1.2 Delivery

Examine the frequency inverter for transport damage or loose components **immediately** on delivery / unpacking.

In case of damage, contact the carrier immediately and arrange for a careful survey.

**Important! This also applies if the packaging is undamaged.**

### 1.3 Scope of delivery

#### **NOTICE**

##### **Defect in the device**

Use of impermissible accessories and options (e.g. also options for other inverter series) may result in defects of interconnected components.

- Only use accessories and options which are explicitly intended for use with this device and stated in this manual.

---

##### *Standard version:*

- Device with IP65 version
- Operating instructions as PDF file on CD ROM including NORDCON software

## 1.4 Presentation conventions

### 1.4.1 Warning information

Warning information for the safety of users are marked as follows:

#### **DANGER**

This warning information warns of danger to persons that results in severe injuries or death.

#### **WARNING**

This warning information warns of danger to persons that could result in severe injuries or death.

#### **CAUTION**

This warning information warns of danger to persons that could usually result in moderate injuries.

#### **NOTICE**

This warning information warns of material damage.

### 1.4.2 Other information

#### **Information**

This information shows tips and important information.

## 1.5 Safety, installation and application information

Before working on or with the device, please read the following safety instructions extremely carefully. Please pay attention to all other information from the device manual.

Non-compliance can result in serious or fatal injuries and damage to the device or its surroundings.

**These safety instructions must be kept in a safe place!**

### 1. General

Do not use defective devices or devices with defective or damaged housings or missing covers (e.g. blind plugs). Otherwise, there is a risk of serious injury or death from electric shock.

Unauthorised removal of covers, improper use, incorrect installation or operation causes a risk of serious personal injury or material damage.

During operation, depending on their protection class, devices may have live bare components as well as hot surfaces.

The device operates with a dangerous voltage. Dangerous voltage may be present at the supply lines, contact strips and PCBs of all connecting terminals (e.g. mains input, motor connection), even if the device is not working or the motor is not rotating (e.g. caused by electronic disabling, jamming of the drive or a short circuit at the output terminals).

The device is not equipped with a mains switch and is therefore always live when connected to the power supply. Voltages may therefore be connected to a connected motor at standstill. An optional mains connection outlet is also at mains voltage.

Even if the drive unit has been disconnected from the mains, a connected motor may rotate and possibly generate a dangerous voltage.

If you come into contact with dangerous voltage such as this, there is a risk of an electric shock, which can lead to serious or fatal injuries.

Power plug connectors must not be pulled out when they are connected to the power supply. Failure to comply with this may cause arcing, which in addition to the risk of injury, also results in a risk of damage or destruction of the device.

The fact that the status LED or other indicators are not illuminated does not indicate that the device has been disconnected from the mains and is without voltage.

Metal components and the housing of power plug connectors may heat up to temperatures of more than 70°C.

Touching these parts can result in local burns to the body parts concerned (cooling times and clearance from neighbouring components must be complied with).

All work on the device, e.g. transportation, installation, commissioning and maintenance work must be carried out by qualified experts (observe IEC 364 or CENELEC HD 384 or DIN VDE 0100 and IEC 664 or DIN VDE 0110 and national accident prevention regulations). In particular, the general and regional installation and safety regulations for work on high voltage systems (e.g. VDE) must be complied with as must the regulations concerning correct use of tools and the use of personal protection equipment.

During all work on the device, take care that no foreign bodies, loose parts, moisture or dust enter or remain in the device (risk of short circuit, fire and corrosion).

Further information can be found in this documentation.

### *Triggering of a circuit breaker*

If the device is secured by a circuit breaker and if this was triggered, this may indicate that a residual current was interrupted. A component (e.g. device, cable or plug connector) in this circuit may have caused an overload (e.g. short circuit or earth fault).

A direct reset of the circuit breaker may lead to the circuit breaker not being triggered afterwards although the fault cause is still present. As a result, any current flowing into the fault location may cause overheating and ignite the surrounding material.

After each triggering of a circuit breaker, all live components within this circuit must thus be visually checked for defects and flashover tracks. Also check the connections at the device's connection terminals.

In case of no faults found or after the replacement of the defect components, switch on the power supply by resetting the circuit breaker. Carefully observe the components keeping a safe physical distance. As soon as you observe a malfunction (e.g. smoke, heat or unusual odours), the occurrence of a new fault or if the status LED on the device does not light up, switch off the circuit breaker immediately and disconnect the defect component from the mains. Replace the defect component.

## **2. Qualified specialist personnel**

Within the meaning of this basic safety information, qualified specialist personnel are persons who are familiar with the installation, assembly, commissioning and operation of the product and who have the qualifications appropriate to their work.

In addition, the device and the accessories associated with it must only be installed and commissioned by a qualified electrician. A qualified electrician is a person who, because of his/her technical training and experience, has sufficient knowledge with regard to

- switching on, switching off, disconnection, earthing and labelling of electric circuits and devices,
- correct maintenance and use of protective devices according to specified safety standards.

## **3. Correct purpose of use – general**

The Motor starters are devices for industrial and commercial plants for operating three-phase asynchronous motors with squirrel-cage rotors.

The devices are components intended for installation in electrical systems or machines.

Technical data and information for connection conditions can be found on the rating plate and in the documentation, and must be complied with.

The devices may only be used for safety functions which are described and explicitly approved.

CE-labelled devices fulfil the requirements of the Low Voltage Directive 2014/35/EU. The stated harmonized standards for the devices are used in the declaration of conformity.

**a. Supplement: Correct purpose of use within the European Union**

When installed in machines, the devices must not be commissioned (i.e. commencement of proper use) until it has been ensured that the machine fulfils the provisions of EC Directive 2006/42/EC (Machinery Directive); EN 60204-1 must also be complied with.

Commissioning (i.e. start-up of proper use) is only permitted if the EMC directive (2014/30/EU) has been complied with.

**b. Supplement: Correct purpose of use outside the European Union**

The local conditions of the operator for the installation and commissioning of the device must be complied with at the usage location (see also "a) Supplement: Correct purpose of use within the European Union").

**4. Do not make any modifications.**

Unauthorised changes and the use of spare parts and additional equipment not purchased from or recommended by NORD may cause fire, electric shock and injury.

Do not change the original coating / paint or apply additional coatings / paints.

Do not make any structural modifications to the product.

**5. Phases of life**

*Transport, storage*

The information in the manual regarding transport, storage and correct handling must be complied with.

The permissible mechanical and climatic ambient conditions (see technical data in the manual for the device) must be complied with.

If necessary, suitable, adequately dimensioned means of transport (e.g. lifting gear, rope guides) must be used.

*Installation and assembly*

The installation and cooling of the device must be implemented according to the regulations in the corresponding documentation. The permissible mechanical and climatic ambient conditions (see technical data in the manual for the device) must be complied with.

The device must be protected against impermissible loads. In particular, components must not be deformed and/or insulation distances must not be changed. Touching of electronic components and contacts must be avoided.

The device and its optional modules contain electrostatically sensitive components, which can be easily damaged by incorrect handling. Electrical components must not be mechanically damaged or destroyed.

*Electrical connection*

Ensure that the device and the motor are specified for the correct supply voltage.

Installation, maintenance and repair work must not be carried out unless the device has been disconnected from the voltage and at least 5 minutes have elapsed since the mains was switched off! (Due to charged capacitors, hazardous voltages may be present on the device for up to 5 minutes)

after being switched off from the mains). Before starting work it is essential to check by measurement that all contacts of the power plug connections or the connection terminals are voltage-free.

The electrical installation must be implemented according to the applicable regulations (e.g. cable cross-section, fuses, earth lead connections). Further instructions can be found in the documentation or manual for the device.

Information regarding EMC-compliant installations such as shielding, earthing, location of filters and routing of cables can be found in the documentation for the devices and in the technical information manual [TI 80-0011](#). This information must always be observed even with devices with a CE label. Compliance with the limit values specified in the EMC regulations is the responsibility of the manufacturer of the system or machine.

In case of a fault, inadequate earthing may result in electric shock, possibly with fatal consequences.

The device may only be operated with effective earth connections which comply with local regulations for large leakage currents (> 3.5 mA). Detailed information regarding connections and operating conditions can be obtained from the technical Information manual [TI 80-0019](#).

Connection of the supply voltage may directly or indirectly set the device into operation. Contact with electrically live components may result in electric shock, possibly with fatal consequences.

All poles of cable connections (e.g. power supply) must always be disconnected.

#### *Setup, troubleshooting and commissioning*

When working on live devices, the applicable national accident prevention regulations must be complied with.

Connection of the supply voltage may directly or indirectly set the device into operation. Contact with electrically live components may result in electric shock, possibly with fatal consequences.

The parametrisation and configuration of the devices must be selected so that no hazards can occur.

With certain setting conditions, the device or the motor which is connected to it may start automatically when the mains are switched on. The machinery which it drives (press / chain hoist / roller / fan etc.) may then make an unexpected movement. This may cause various injuries, including to third parties.

Before switching on the mains, secure the danger area by warning and removing all persons from the danger area.

#### *Operation*

Where necessary, systems in which the devices are installed must be equipped with additional monitoring and protective equipment according to the applicable safety requirements (e.g. legislation concerning technical equipment, accident prevention regulations, etc.).

All covers must be kept closed during operation.

With certain setting conditions, the device or the motor which is connected to it may start automatically when the mains are switched on. The machinery which it drives (press / chain hoist / roller / fan etc.) may then make an unexpected movement. This may cause various injuries, including to third parties.

Before switching on the mains, secure the danger area by warning and removing all persons from the danger area.

#### *Maintenance, repair and decommissioning*

Installation, maintenance and repair work must not be carried out unless the device has been disconnected from the voltage and at least 5 minutes have elapsed since the mains was switched off! (Due to charged capacitors, hazardous voltages may be present on the device for up to 5 minutes after being switched off from the mains). Before starting the work, it is essential to check by measurement that all contacts of the power plug connectors or the connection terminals are voltage-free.

### *Disposal*

The product and its parts and accessories must not be disposed of as domestic waste. At the end of its life, the product must be properly disposed of according to the local regulations for industrial waste. In particular, this product contains integrated semiconductor circuits (PCBs and various electronic components, including high power electrolytic capacitors). In case of incorrect disposal there is a risk of formation of toxic gases, which may cause contamination of the environment and direct or indirect injuries (e.g. chemical burns). In the case of high power electrolytic capacitors, there is also a risk of explosion, with the associated risk of injury.

### **6. Potentially explosive environment (ATEX)**





The device is not approved for operation or maintenance work in potentially explosive environments (ATEX).

## 1.6 Warning and hazard information

Under certain circumstances, hazardous situations may occur in association with the frequency inverter. In order to give explicit warning of possibly hazardous situations, clear warning and hazard information can be found on the device and in the relevant documentation.

### 1.6.1 Warning and hazard information on the product

The following warning and hazard information is used on the product.







Symbol	Supplement to symbol <sup>1)</sup>	Meaning
	DANGER Device is live > 5min after removing mains voltage	<p><b>Danger</b> <b>Electric shock</b></p> <p>The device contains powerful capacitors. Because of this, there may be a hazardous voltage for more than 5 minutes after disconnection from the mains.</p> <p>Before starting work, check that the device is free of voltage at all power contacts by means of suitable measuring equipment.</p>
		It is essential to read the manual in order to prevent hazards!
		<p><b>CAUTION</b> <b>Hot surfaces</b></p> <p>The heat sink and all other metal components as well as the surfaces of plug connectors may heat up to temperatures in excess of 70°C.</p> <ul style="list-style-type: none"> <li>• Danger of injury due to local burns on contact.</li> <li>• Heat damage to adjacent objects</li> </ul> <p>Allow sufficient cooling time before starting work on the device. Check the surface temperatures with suitable measuring equipment. Maintain an adequate distance to adjacent components or provide protection against contact.</p>
		<p><b>NOTICE</b> <b>EDS</b></p> <p>The device contains electrostatically sensitive components, which can be easily damaged by incorrect handling.</p> <p>Avoid all contact (indirect contact by tools or similar, or direct contact) with PCBs and their components.</p>

1) Texts are written in English.

Table 2: Warning and hazard information on the product

## 1.7 Standards and approvals

All devices across the entire series comply with the standards and directives listed below.

Approval	Directive	Applied standards	Certificates	Label
CE (European Union)	Low Voltage 2014/35/EU	EN 60947-1 EN 60529 EN 60947-4-2 EN 63000	C310801	
	EMC 2014/30/EU			
	RoHS 2011/65/EU			
	Delegated directive (EU) 2015/863			
UL (USA)		UL 60947-1 UL 60947-4-2	E365221	
CSA (Canada)		C22.2 No.UL 60947-1-13 C22.2 No.UL 60947-4-2-14	E365221	
RCM (Australia)	F2018L00028	EN 60947-1 EN 60947-4-2	133520966	
EAC (Eurasia)	TR CU 004/2011, TR CU 020/2011	IEC 60947-1 IEC 60947-4-2	EAЭC N RU Д- DE.HB27.B.02731/ 20	
UkrSEPRO (Ukraine)		EN 60947-1 EN 60529 EN 60947-4-2 EN 63000 EN 60947-1 EN 60947-4 EN 61558-1 EN 50581	C311900	
UKCA (United Kingdom)		EN 60947-1 EN 60529 EN 60947-4-2 EN 63000 EN 61800-9-1 EN 61800-9-2	C350801	

**Table 3: Standards and approvals**

### 1.7.1 UL and CSA approval

#### File No. E365221

The categorisation of protective equipment approved by the UL according to United States standards for the devices described in this manual is listed below, basically with the original wording. The categorisation of the individually relevant fuses or circuit breakers can be found in the “Electrical Data” section of this manual.

All devices include motor protection.

(7.2 "Electrical data ")

**i Information**

**Group fuse protection**

The devices can be protected as a group via one common fuse (see below for details). Pay attention to compliance with the total currents and the use of correct cables and cable cross-sections. If the device is mounted close to the motor, this also applies to the motor cables.

**Conditions UL/CSA according to report**

**i Information**

“Use 60/75°C copper field wiring conductors.”

„These products are intended for use in a pollution degree 2 environment“

“Maximum ambient temperatur 50°C”

“The source shall be derived from a non-corner grounded type TN with max. Impulse Voltage of 4 kV and not exceeding 289 V phase to earth or from IT source with max. Impulse voltage of 6 kV not exceeding 500 V (or equivalent) or devices with the suffix –IT.”

Size	valid	description
1	generally valid	<p>Only for use with Connectors from HARTING ELECTRIC GMBH &amp; CO KG, LQ Mechatronic Systems GmbH and Intercontec Produkt GmbH: “Suitable For Use On A Circuit Capable Of Delivering Not More Than 5 000 rms Symmetrical Amperes, 500 Volts Maximum” “When Protected by class RK5 Fuses or faster.</p> <p>“Suitable For Use On A Circuit Capable Of Delivering Not More Than _____ rms Symmetrical Amperes, 500 Volts Max., When Protected by High-Interrupting Capacity, Current Limiting Class CA, CC, CF, G, J, T Fuses.” The short circuit rating (max. 65 000A) is based on the Connectors (Details listed below) and will be printed during production. Details listed in <sup>1)</sup>.</p> <p>“Suitable For Use On A Circuit Capable Of Delivering Not More Than _____ rms Symmetrical Amperes, 500 Volt maximum”</p> <p>“When Protected by Circuit Breaker (inverse time trip type) in accordance with UL 489” The short circuit rating (max. 10 000) is based on the Connectors (Details listed below) and will be printed during production. Details listed in <sup>1)</sup>.</p>
	<b>Motor group installation (Group fusing):</b>	<p>Only for use with Connectors from HARTING ELECTRIC GMBH &amp; CO KG, LQ Mechatronic Systems GmbH and Intercontec Produkt GmbH: “Suitable for motor group installation on a circuit capable of delivering not more than 5000 rms symmetrical amperes, 500 V max” “When Protected by class RK5 Fuses or faster, rated max. 30Amperes”, as listed below.</p> <p>“Suitable for motor group installation on a circuit capable of delivering not more than _____rms symmetrical amperes, 500 V max” “When Protected by High-Interrupting Capacity, Current Limiting Class CA, CC, CF, G, J, T Fuses, rated max. 30A”. The short circuit rating (max. 65 000 A) is based on the Connectors (Details listed below) and will be printed during production. Details listed in <sup>1)</sup>.</p> <p>“Suitable for motor group installation on a circuit capable of delivering not more than _____rms symmetrical amperes, 500 V max” “When Protected by Circuit Breaker (inverse time trip type) in accordance with UL 489, rated max. 30 Amperes” The short circuit rating (max. 10 0000) is based on the Connectors (Details listed below) and will be printed during production. Details listed in <sup>1)</sup>.</p>
	<b>differing data CSA:</b>	None differing data → equal to UL

1) (E 7.2 “Electrical data ”)

**i Information**

**Connector optional**

Cat. No.	manufactured by	rated voltage	rated current	Fuse size		SCCR, RMS
09 12 003 3051 (HAN Q3/0-M)	HARTING ELECTRIC GMBH & CO KG	600 V	17 – 41.5 A			65 kA
09 12 003 3151 (HAN Q3/0-F)	HARTING ELECTRIC GMBH & CO KG	600 V	17 – 41.5 A			65 kA
09 12 006 3041 (HAN Q4/2 M)	HARTING ELECTRIC GMBH & CO KG	600 V	11 – 25 A			65 kA
09 12 006 3141 (HAN Q4/2 F)	HARTING ELECTRIC GMBH & CO KG	600 V	11 – 25 A			65 kA
09 12 005 3001 (HAN Q5/0-M)	HARTING ELECTRIC GMBH & CO KG	600 V	11 – 16 A			65 kA
09 12 005 3101 (HAN Q5/0-F)	HARTING ELECTRIC GMBH & CO KG	600 V	11 – 16 A			65 kA
09 12 008 3001 (HAN Q8/0 M)	HARTING ELECTRIC GMBH & CO KG	600 V	10 – 18 A			65 kA
09 12 008 3101 (HAN Q8/0 F)	HARTING ELECTRIC GMBH & CO KG	600 V	10 – 18 A			65 kA
09 12 002 3051 (HAN Q2/0-M)	HARTING ELECTRIC GMBH & CO KG	600 V	19 – 47.5 A			65 kA
09 12 002 3151 (HAN Q2/0-F)	HARTING ELECTRIC GMBH & CO KG	600 V	19 – 47.5 A			65 kA
QPD W 3PE2.5...M25	PHOENIX CONTACT GMBH & CO. KG	600 V	10 – 15 A		J, T, CC	5 kA
QPD 4P M25 WHQM	PHOENIX CONTACT GMBH & CO. KG	600 V	8 – 12 A		J, T, CC	5 kA
P29036	AMPHENOL SINE SYSTEMS CORP	600 V	25 A	30 A	J, T, CC, CB: 30A	65 kA
P29039	AMPHENOL SINE SYSTEMS CORP	600 V	30 A	30 A	J, T, CC	65 kA

## 1.8 Type code / nomenclature

The type code of the device depicts the basic features. A unique identification of the device including all customer-specific features is only possible via the device's order or serial number.

### 1.8.1 Type plate

All of the information which is relevant for the frequency inverter, including information for identification of the device can be obtained from the type plate.

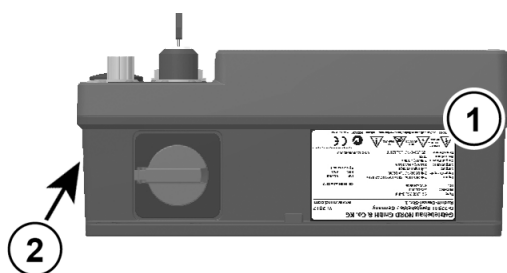

(1)

Type:	SK 1x5E-FDS-301-340-A HWR-HVS-...
Part No.:	5050601-100
ID:	27Q303614961
Version:	AAA 1.0R0

<b>Type:</b>	Type / designation
<b>Part No.:</b>	Order number
<b>ID:</b>	Identification number
<b>Version:</b>	Hardware / Software version

### 1.8.2 Plates with additional information

Two additional plates which contain additional technical data regarding UL/cUL are attached to the right-hand side of the device.

#### 1.8.2.1 Warning information

This warning information is attached in general.

Plate text	Meaning
<p><b>DANGER</b> -The opening of the branch-circuit protective device may be an indication that a fault current has been interrupted.</p> <p>To reduce the risk of fire or electrical shock, current-carrying parts and other components, of the controller should be examined and replaced if damaged. If burnout of the current element of an overload relay occurs, the complete overload relay must be replaced.</p>	<p><b>DANGER</b> - Triggering the junction protective device can be an indicator that a residual current was interrupted.</p> <p>To reduce the risk of fire or electric shock, live parts and other components must be checked and replaced in case of damage. If the power element of an overload relay burns out the complete overload relay must be replaced.</p>

#### 1.8.2.2 Information regarding the power plug connectors

This second plate depends on the power plug connectors which are used.

Manufacturer	Plate text	Meaning
Amphenol	<p><b>SCCR:</b> 65 kA, 500 V, BCP Fuse, Class CC, J, T  <b>SCCR:</b> 10 kA, 500 V, BCP CB</p> <p>BCP Rating and further Short Circuit Rating  see manual</p> <p>Suitable for group fusing</p> <p><b>SCCR Group Installation:</b>  same except BCP Fuse or CB rated max. 30 A</p>	
HARTING	<p><b>SCCR:</b> 65 kA, 500 V, BCP Fuse, Class CA, CC, CF, G, J, T  <b>SCCR:</b> 5 kA, 500 V, BCP Fuse, Class RK5 or faster  <b>SCCR:</b> 10 kA, 500 V, BCP CB</p> <p>BCP Rating and further Short Circuit Rating  see manual</p> <p>Suitable for group fusing</p> <p><b>SCCR Group Installation:</b>  same except BCP Fuse or CB rated max. 30 A</p>	
Phönix	<p><b>SCCR:</b> 5 kA, 500 V, BCP Fuse, Class CC, J, T</p> <p>BCP Rating and further Short Circuit Rating  see manual</p> <p>Suitable for group fusing</p> <p><b>SCCR Group Installation:</b>  same except BCP Fuse or CB rated max. 30 A</p>	

( 2 ) Two further plates which contain the supplementary electrical data for UL/cUL are affixed to the right hand side of the device.

**First plate**

This warning information is attached in general.

**DANGER** -The opening of the branch-circuit protective device may be an indication that a fault current has been interrupted.

To reduce the risk of fire or electrical shock, current-carrying parts and other components, of the controller should be examined and replaced if damaged. If burnout of the current element of an overload relay occurs, the complete overload relay must be replaced.

**Second plate**

The second plate depends on the power plug connectors which are used.

Amphenol

**SCCR:** 65 kA, 500 V, BCP Fuse, Class CC, J, T  
**SCCR:** 10 kA, 500 V, BCP CB

BCP Rating and further Short Circuit Rating  
 see manual

Suitable for group fusing

**SCCR Group Installation:**  
 same except BCP Fuse or CB rated max. 30 A

HARTING

**SCCR:** 65 kA, 500 V, BCP Fuse, Class CA, CC, CF, G, J, T  
**SCCR:** 5 kA, 500 V, BCP Fuse, Class RK5 or faster  
**SCCR:** 10 kA, 500 V, BCP CB

BCP Rating and further Short Circuit Rating  
 see manual

Suitable for group fusing

**SCCR Group Installation:**  
 same except BCP Fuse or CB rated max. 30 A

Phoenix

**SCCR:** 5 kA, 500 V, BCP Fuse, Class CC, J, T

BCP Rating and further Short Circuit Rating  
 see manual

Suitable for group fusing

**SCCR Group Installation:**  
 same except BCP Fuse or CB rated max. 30 A

### 1.8.3 Field Distribution System type code

SK 175E-FDS-301-340-A-XXX

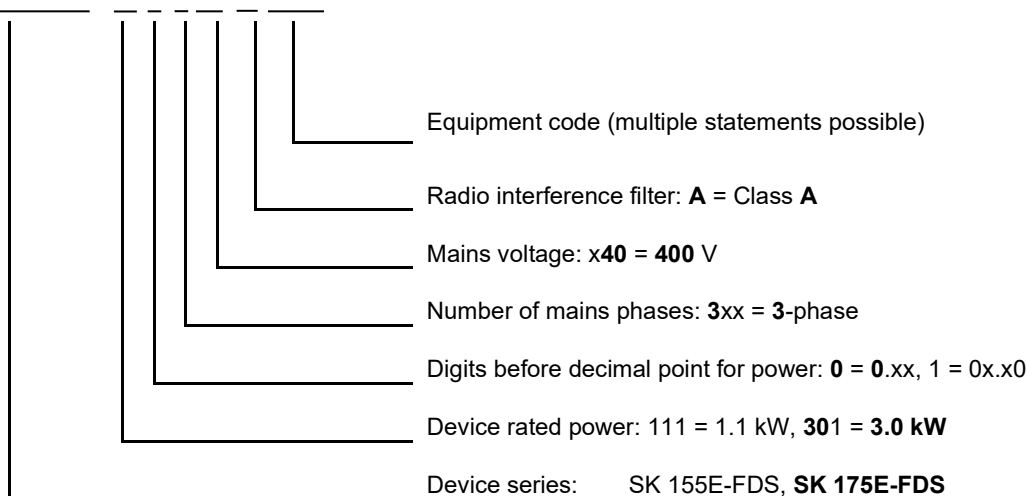

### Configuration code

	Meaning
-AS-i	Actuator-sensor interface with "AS-i" connector option
-ASS	Actuator-sensor interface with "ASS" connector option
-AUX	Actuator-sensor interface with "AUX" connector option
-AXS	Actuator-sensor interface with "AXS" connector option
-BWRN	Integrated brake rectifier for controlling a 205 V DC brake
-HVS	Integrated 24 V DC power supply unit
-HWR	Integrated brake rectifier for controlling a 180 V DC brake
-PBR	Profibus interface
-TIDIO	With the aid of the -TIDIO option, the digital IOs of the motor starter are connected to the corresponding IOs of an SK CU4 module in the device.
-USB	RS232/RS485 interface: USB port in place of the RJ12 port. <b>Note:</b> Parameterisation units cannot be connected to the USB port. Parameterisation and diagnosis are only possible via a PC with NORDCON software.

### 1.9 Version with protection class IP65

The motor starter of the field distributor series SK 1x5E-FDS meets the following IP protection class:

- IP65



#### Information

##### Cable laying

Make sure that the cables and cable glands comply at least with the devices protection class and the mounting regulations, and are carefully matched to each other.

## 2 Assembly and installation

No options can be retrofitted. All options must be recorded by NORD when ordering and before the production process. The customer must not open the device at any time and does not need to. The device is mounted by using mounting lugs that are freely accessible from the outside. The electrical connection of mains, motor and signal cables is only possible via respective plug connectors. The optionally available control elements (e.g. switches) are mounted in a freely accessible position.

Opening a defined blind plug is only required for the temporary connection of a diagnostic tool. The diagnostic tools comprise:

- Parameterisation unit SK CSX-3H/ SK PAR-3H
- NORDAC *ACCESS BT* with the NORDCON *APP*
- PC with the NORDCON software

Various configurations of the FI can also be made during commissioning via the integrated DIP switches or potentiometers. Access to these elements is also via the corresponding blank plugs.

## 2.1 Installation

The devices are designed for an installation close to the motor and do not need a control cabinet due to their protection class.

**Distance from device:** The devices require sufficient ventilation for protection against overheating and must therefore not be covered.

Mounting can be immediately next to each other.

The required distances for the connection cable routing must be maintained.

**Installation position:**

- Vertical, i.e. bottom position of cable connection (power connection)
- Horizontal, i.e. top position of control elements and diagnostic LEDs

See also the following illustration.

### Dimensions:

Power [kW]		Device type SK 1xxE-FDS-...		Size	Housing dimensions					Wall mounting				Weight <sup>2)</sup> (approx.)			
From	to		to		A	M	L <sup>1)</sup>	L1	L2	X1	X2	X3	∅				
0.06	1.1		111-340-...	0	243	104	312	294	243	110	193	263	5.5	3.0			
> 0,55 <sup>3)</sup>	3.0		301-340-...	1	All dimensions in [mm]												
														[kg]			

1) Without maintenance switch: 307 mm

2) Depending on configuration approx. +/- 0.5 kg

3) Note: For proper control behaviour the motor power has to be at least 0.55 kW

### Sizes 0 and 1

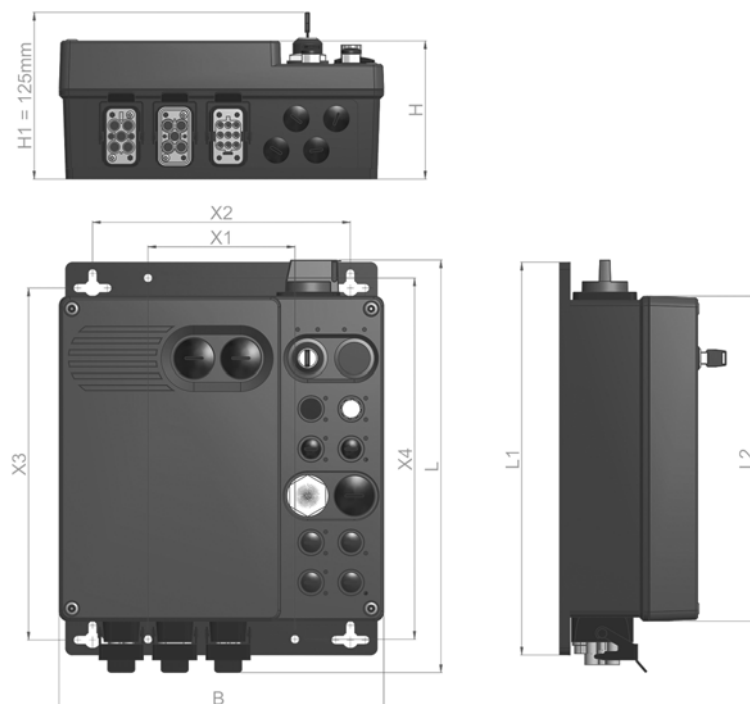

### 2.2 Option slots and equipment versions

The device is configured according to the customer specification. No options can be retrofitted. All options must be recorded by NORD when ordering and before the production process.

Defined positions on the device apply for the selected options and features. Dependencies between the selected options and on relevant signalling devices (LEDs) or parameter settings are explained in this instruction.

#### 2.2.1 Option slots

The device is divided into 3 levels. Each of these levels is intended for the installation of certain options or option groups.

##### 2.2.1.1 Connection level

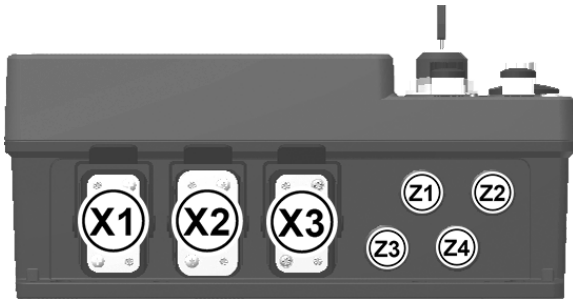

**Position:** bottom

The configuration and assignment of the power connections (mains and motor connections) depends on the customer's specification for the product.

This also applies for the additional option slots for the signal connections.

**X1 =** Power connection 1

... ..

**X3 =** Power connection 3

**Z1 =**

... Additional signal connections

**Z4 =**

### 2.2.1.2 Control level

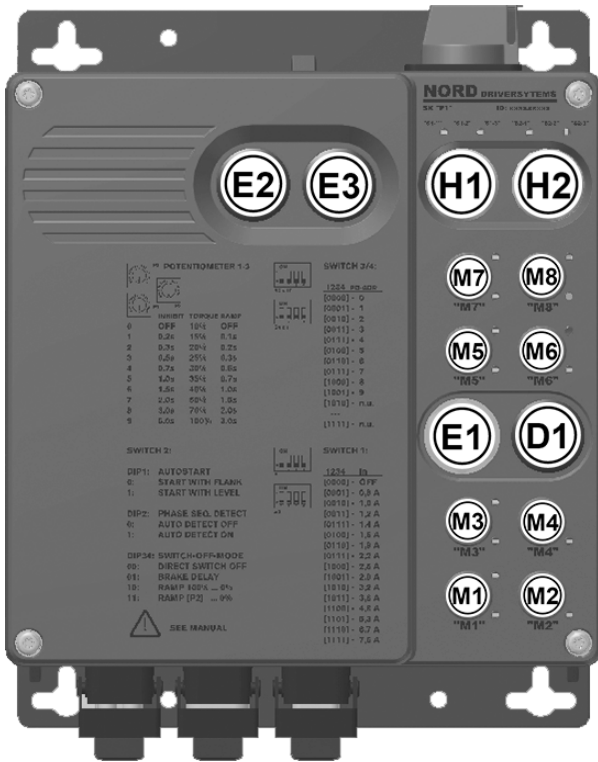

**Position:** front

The configuration and functions of the individual option slots are variable. They are directly influenced by the customer's specification, but are also indirectly dependent on the further features.

The meaning of the LEDs which are assigned for each option slot is also dependent.

- D1** = Diagnostic opening
- E1** = DIP switches
- E2** = Potentiometers
- E3** = DIP switches (PROFIBUS address) – only for device versions SK 1x5E-...-PBR
- H1** = Control element 1
- H2** = Control element 2
- M1** =
- ... Signal connections
- M8** =

## Information

### Blind plug removal

You can access the potentiometers and DIP switches by removing the blind plugs. Remove the blind plugs only for commissioning and replace them properly afterwards. Make sure that no moisture or dirt enters the device.

### 2.2.1.3 Maintenance switch level

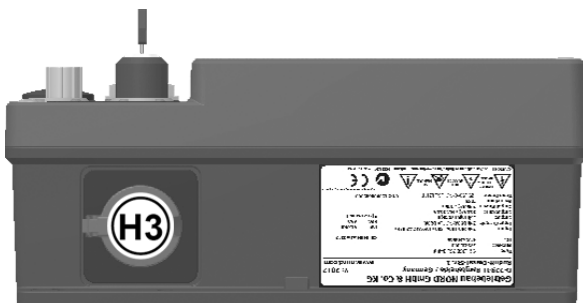

**Position:** top

The configuration and function of other option slots may be influenced by the maintenance switch.

**H3** = Maintenance switch

### 2.2.2 Configuration versions

The device offers various interfaces in the form of plug connections. This makes it possible to configure the device according to the individual requirements on the drive task.

The arrangement of the interfaces on the device is different depending on the device configuration. One option slot has exactly one option type.

The following tables show which features can be combined and the influence they have on the respective option slots.

Furthermore, using initiators or actuators allows for reading the related parameters and the valid factory settings.

#### 2.2.2.1 Configurable options

The following integrated features can be configured. Selection of the options must be made when the frequency inverter is ordered. Subsequent changes to the configuration are not possible.

	Meaning
-AS-i	Actuator-sensor interface with "AS-i" connector option
-ASS	Actuator-sensor interface with "ASS" connector option
-AUX	Actuator-sensor interface with "AUX" connector option
-AXS	Actuator-sensor interface with "AXS" connector option
-BWRN	Integrated brake rectifier for controlling a 205 V DC brake
-HVS	Integrated 24 V DC power supply unit
-HWR	Integrated brake rectifier for controlling a 180 V DC brake
-PBR	Profibus interface
-TIDIO	With the aid of the -TIDIO option, the digital IOs of the motor starter are connected to the corresponding IOs of an SK CU4 module in the device.
-USB	RS232/RS485 interface: USB port in place of the RJ12 port. <b>Note:</b> Parameterisation units cannot be connected to the USB port. Parameterisation and diagnosis are only possible via a PC with NORDCON software.

### 2.2.2.2 Configuration of option slots of the control level

The option slots **M1** to **M8** are designed for M12 plug connectors. The device-relevant assignment of the connections or functions of the individual option slots is directly printed on the optional slot.

Option slot	Option type	Function	Relevant parameter	Comment	
M1	a	No option			
	b	Initiator 1/2	BDI1 BDI2	P420[-09] P420[-10]	
M2	a	No option			
	b	Initiator 2	BDI2	P420[-10]	
M3	a	No option			
	b	Actuator 1/2	DOUT1 DOUT2	P434[-01] P434[-02]	
M4	a	No option			
	b	Actuator 2	DOUT2	P434[-02]	
M5	a	No option			
	b	Initiator 3/4	DIN1	P420[-01]	
			DIN2	P420[-02]	
	c	Initiator 4/5	DIN2	P420[-02]	
DIN3			P420[-03]		
d	PROFIBUS DP (input)	PBR (Bus In)		only SK 1x5E-FDS-...PBR	
M6	a	No option			
	b	Initiator 4	DIN2	P420[-02]	
M7	a	No option			
	b	Initiator 3/4	DIN1	P420[-01]	
			DIN2	P420[-02]	
c	PROFIBUS DP (output)	PBR (Bus Out)		only SK 1x5E-FDS-...PBR	
M8	a	No option			
	b	24 V DC supply <sup>1)</sup>	24VI		
	c	AS-Interface ("AUX")	AUX		only SK 1x5E-FDS-...Axx
	d	AS-Interface ("AS-i")	ASI		
	e	AS-Interface ("AXS")	AXS		
	f	AS-Interface ("ASS")	ASS		

1) The 24 V DC control voltage can also be supplied via **M8 c** (AUX), **M8 e** (AXS) or the option slots **X1** or **Z1** ... **Z4** of the connection level.

The device's control elements are located at the option slots **H1** and **H2**.

Different control elements can be selected. Depending on the selected combination, they can influence the functions of individual digital inputs. These functions are device-specific in the factory settings of the respective parameter.

Variant	Option slot H1 <sup>1)</sup>		Option slot H2 <sup>2)</sup>		Parameter function		
	Type	Function	Type	Function	P420[-01]	P420[-02]	P420[-03]
0	-	/	-	/	{1}	{2}	{0}
1	I	L - A - R	-	/	{1}	{2}	{0}
2	I	L - A - R	IV	/ - Q	{1}	{2}	{7}
3	II	A - L	-	/	{1}	{0}	{0}
4	II	A - L	II	Off - On	{10}	{0}	{1}
5	II	A - L	I	L - Off - R	{10}	{2}	{1}
6	III	Q - A - L	-	/	{1}	{7}	{0}
7	III	Q - A - L	II	Off - On	{10}	{7}	{1}
<b>Functions</b>							
<b>A</b>	Automatic mode active		<b>L</b>	Manual mode active		<b>L</b>	Manual mode, Enable left
<b>R</b>	Manual mode, Enable right		<b>Off</b>	Manual mode, Not enabled		<b>On</b>	Manual mode, Enabled
						<b>Q</b>	Fault acknowledgement
<b>Operating option type</b>							
I	Switch (left – centre – right), locking, switch or key switch version						
II	Switch (centre – right), locking, switch or key switch version						
III	Switch (left – centre – right), locking at centre and right, switch or key switch version						
IV	Pushbutton						

1) Influence on parameter functions of digital inputs DIN 1/2

2) Influence on parameter functions of digital inputs DIN 2/3

### Plug connections for M12 plug connectors

Depending on the function, 5-pin M12 surface mounted plug connectors with coloured sockets or plug inserts are installed. The colours reflect the functional assignment of the plug connector and therefore enable easy identification on the FI. The same applies for the colour coding of the cover caps.

The following plug connectors may be used on the device, depending on the customer's specification.

### Option slots M1 to M8

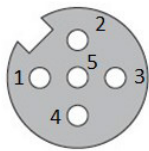
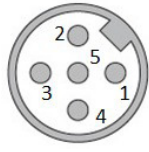
Function	Plug connector		Contact assignment					Option slot	
	Contact diagram		1	2	3	4	5	No.	Colour
DIN1 / DIN2	 Socket, A-coded		24 V	DIN2	GND	DIN1	PE	M5, M7	Black and white
DIN2 / DIN3			24 V	DIN3	GND	DIN2	PE	M5	Black and white
DIN2			24 V		GND	DIN2	PE	M6	Black and white
BDI1 / BDI2			24 V	BDI2	GND	BDI1	PE	M1	Black and white
BDI2			24 V		GND	BDI2	PE	M2	Black and white
DOUT1 / DOUT2			24 V	DOUT2	GND	DOUT1	PE	M3	Black and white
DOUT2			24 V		GND	DOUT2	PE	M4	Black and white
24VI	 Plug connectors, A-coded		24 V		GND			M8	Black and white
ASI			ASI+		ASI-			M8	Yellow
ASS			ASI+		ASI-			M8	Yellow
AUX			ASI+	GND	ASI-	24 V		M8	Yellow
AXS			ASI+	GND	ASI-	24 V		M8	Yellow

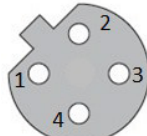
Function	Plug connector Contact diagram	Contact assignment					Option slot	
		1	2	3	4	5	No.	Colour
PBR (Bus-IN) <sup>1)</sup>	 Plug connectors, B-coded		PBR A		PBR B		M5	Violet
PBR (Bus OUT) <sup>1)</sup>	 Socket, B-coded	5 V	PBR A	GND	PBR B		M7	Violet

1) The plug connector's housing is internally wired to PE.

### Information

Connection material, e.g. T-connectors for connection of double initiators, for looping an external 24 V DC supply or an STO signal, can be obtained commercially or can be obtained from NORD on request.

### 2.2.2.3 Configuration of option slots on the connection level

The connection level of the field distribution frequency inverter is divided into 2 areas.

**DANGER**



**Electric shock at X2**

An optional **mains connection outlet (LA)** on option slot **X2** can also not be switched off with a repair and maintenance switch (option slot **H3**). This may therefore still be at mains voltage.

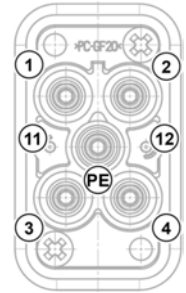

- Do not touch any contacts.
- Disconnect the device from the mains (mains supply, option slot **X1**).

#### Area 1, option slots X1 to X3

Typical machinery connectors are used. These are primarily used to connect the mains and motor cables. Special connector variants additionally ensure the connection of a PTC resistor or a 24 V DC supply. The plug connectors are equipped with a detachable protective cap. **The mating connector is not included in the scope of delivery.**

Option slot	Plug connector type	Function	LE	Contact assignment													
X1	a HARTING Q4/2+ (plug connector)	Mains connection (supply)	LE														
		4 mm <sup>2</sup> / 25 A (24 V DC: 1.5 mm <sup>2</sup> ) <hr/> 6 mm <sup>2</sup> / 30 A (without 24 V DC!)			<table border="1"> <tr> <td>1</td><td>L1</td> <td>2</td><td>L2</td> <td>3</td><td>L3</td> <td>4</td><td>N</td> </tr> <tr> <td>PE</td><td>PE</td> <td>11</td><td>24 V DC</td> <td>12</td><td>GND</td> <td></td><td></td> </tr> </table>	1	L1	2	L2	3	L3	4	N	PE	PE	11	24 V DC
1	L1	2	L2	3	L3	4	N										
PE	PE	11	24 V DC	12	GND												
	b PHOENIX QPD-25 (plug connector)	Mains connection (supply)	LE														
		2.5 mm <sup>2</sup> / 16 A		<table border="1"> <tr> <td>1</td><td>L1</td> <td>2</td><td>L2</td> <td>3</td><td>L3</td> <td>PE</td><td>PE</td> </tr> </table>	1	L1	2	L2	3	L3	PE	PE					
1	L1	2	L2	3	L3	PE	PE										
	c Amphenol P29036-M1 (plug connector)	Mains connection (supply)	LE														
		2.5 mm <sup>2</sup> / 16 A		<table border="1"> <tr> <td>1</td><td>L1</td> <td>2</td><td>L2</td> <td>3</td><td>L3</td> <td>4</td><td>PE</td> </tr> </table>	1	L1	2	L2	3	L3	4	PE					
1	L1	2	L2	3	L3	4	PE										

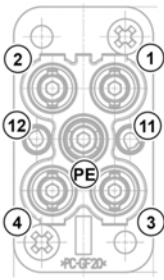
## 2 Assembly and installation

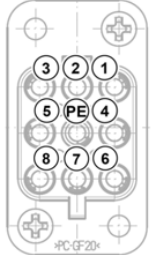
Option slot	Plug connector type	Function	Contact assignment																								
X2	a -	No function	<b>Option slot not used</b>																								
	b HARTING Q4/2+ (socket)	Mains connection (outlet)  4 mm <sup>2</sup> / 25 A <sup>1)</sup> (24 V DC: 1.5 mm <sup>2</sup> )  6 mm <sup>2</sup> / 30 A <sup>1)</sup> (without 24 V DC!)	LA   <table border="1"> <tr> <td>1</td><td>L1</td><td>2</td><td>L2</td><td>3</td><td>L3</td><td>4</td><td>N</td> </tr> <tr> <td>PE</td><td>PE</td><td>11</td><td>24 V DC</td><td>12</td><td>GND</td><td></td><td></td> </tr> </table>	1	L1	2	L2	3	L3	4	N	PE	PE	11	24 V DC	12	GND										
1	L1	2	L2	3	L3	4	N																				
PE	PE	11	24 V DC	12	GND																						
	c PHOENIX QPD-25 (socket)	Mains connection (outlet)  2.5 mm <sup>2</sup> / 16 A	LA   <table border="1"> <tr> <td>1</td><td>L1</td><td>2</td><td>L2</td><td>3</td><td>L3</td><td>PE</td><td></td> </tr> </table>	1	L1	2	L2	3	L3	PE																	
1	L1	2	L2	3	L3	PE																					
	d HARTING Q8/0+ (socket)	Motor connection 2 (outlet)  4 mm <sup>2</sup> / 16 A	MA2   <table border="1"> <tr> <td>1</td><td>U</td><td>2</td><td>nc.</td><td>3</td><td>W</td><td>4</td><td>BR-</td> </tr> <tr> <td>5</td><td>TF+</td><td>6</td><td>BR+</td><td>7</td><td>V</td><td>8</td><td>TF-</td> </tr> <tr> <td>PE</td><td>PE</td><td></td><td></td><td></td><td></td><td></td><td></td> </tr> </table>	1	U	2	nc.	3	W	4	BR-	5	TF+	6	BR+	7	V	8	TF-	PE	PE						
1	U	2	nc.	3	W	4	BR-																				
5	TF+	6	BR+	7	V	8	TF-																				
PE	PE																										
1) For BG0: 20 A, with and without 24 V DC																											

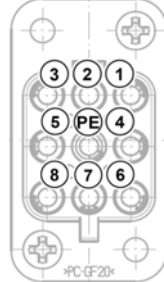
X3	a HARTING Q8/0+ (socket)	Motor connection 1 (output)  4 mm <sup>2</sup> / 16 A	MA   <table border="1"> <tr> <td>1</td><td>U</td><td>3</td><td>W</td><td>4</td><td>BR-</td><td>5</td><td>TF+</td> </tr> <tr> <td>6</td><td>BR+</td><td>7</td><td>V</td><td>8</td><td>TF-</td><td>PE</td><td>PE</td> </tr> </table>	1	U	3	W	4	BR-	5	TF+	6	BR+	7	V	8	TF-	PE	PE
1	U	3	W	4	BR-	5	TF+												
6	BR+	7	V	8	TF-	PE	PE												

## Area 2, option slots Z1 to Z4

The option slots M1 to M8 are designed for M12 plug connectors. No fixed functions are allocated to the option slots. **The mating plug connector is not included in the scope of supply.**

As the built-in plug connector cannot be adjusted during assembly, the use of **angled** cable plug connectors **is not recommended.**

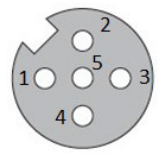
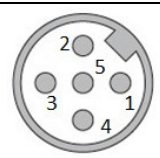
Function	Plug connector <sup>1)</sup>		Contact assignments					Option slot	
	Contact diagram		1	2	3	4	5	No.	Colour
24VO	 <p>Socket, A-coded</p>	24 V		GND				Z1 - Z4	black
24VI	 <p>Plug connectors, A-coded</p>	24 V		GND				Z1 - Z4	black

1) The housing of the plug connectors are internally wired to PE.

### 2.2.2.4 Configuration of the option slot for the maintenance switch level

#### DANGER

#### Electric shock at X2

An optional **mains connection outlet (LA)** on option slot **X2** can also not be switched off with a repair and maintenance switch (option slot **H3**). This may therefore still be at mains voltage.

- Do not touch any contacts.
- Disconnect the device from the mains (mains supply, option slot **X1**).

Option slot **H3** is intended for equipment with an optional repair and maintenance switch. Various versions (e.g. lockable/non-lockable) may be installed.

The repair and maintenance switch disconnects the supply to the device and therefore also the supply to the directly connected motor. For device versions which are intended for passing through the mains voltage, the daisy chain channel is not interrupted. The following devices are still supplied.

### 2.3 Electrical Connection

#### WARNING

##### Electric shock

Dangerous voltages may be present at the plug contacts for the power connections (e.g. mains cable, motor cable) even when the device is not in operation.

- Before starting work, check that all relevant components (voltage source, connection cables) are free of voltage using suitable measuring equipment.
- Use insulated tools (e.g. screwdrivers).
- Earth devices.

#### Information

##### Temperature sensor and PTC (TF)

As with other signal cables, thermistor cables must be laid separately from the motor cables. Otherwise the interfering signals from the motor winding that are induced into the line affect the device.

Ensure that the device and the motor are specified for the correct supply voltage.

Electrical connections are made exclusively with plug connectors.

#### 2.3.1 Wiring guidelines

The devices have been developed for use in an industrial environment. In this environment, electromagnetic interference can affect the device. In general, correct installation ensures safe and problem-free operation. To meet the limiting values of the EMC directives, the following instructions should be complied with.

1. Ensure that all devices are securely earthed to a common earthing point or earthing rail using short earthing cables with a large cross-section. It is especially important that each control unit which is connected to the electronic drive technology (e.g. an automatic device) has a short cable with a large cross-section, which is connected to the same earthing point as the device itself. Flat cables (e.g. metal clamps) are preferable, as they have a lower impedance at high frequencies.
2. The bonding cable of the motor controlled by the soft starter should be connected directly to the earthing terminal of the associated device. The presence of a central earthing bar in the control cabinet and the grouping together of all bonding conductors to this bar normally ensures safe operation.
3. Where possible, shielded cables should be used for control circuits. The shielding at the cable end should be carefully sealed and it must be ensured that the wires are not laid over longer distances without shielding.  
The shielding of analogue setpoint cables should only be earthed on one side on the device.
4. Control cables should be installed as far as possible from power cables, using separate cable ducts, etc. Where cables cross, an angle of 90° should be ensured as far as possible.
5. Ensure that the contactors in the cabinet are interference protected, either by RC circuits in the case of AC contactors or by free-wheeling diodes for DC contactors, for which **the interference suppressors must be positioned on the contactor coils**. Varistors for over-voltage limitation are also effective.

Furthermore, attention must be paid to the EMC-compliant wiring.

***During the installation of the devices, the safety requirements must not be violated under any circumstances!***

## **NOTICE!**

### **Damage due to high voltage**

The device may be damaged by electrical loads which do not correspond to its specification.

- Do not perform any high voltage tests on the device itself.
- Disconnect the cable which is to be tested from the device before performing a high voltage insulation test.

---

If the device is installed according to the recommendations in this manual, it meets all EMC directive requirements, as per the EMC product standard EN 60947-4-2.

### 2.3.2 Electrical connection of power unit

#### NOTICE

##### EMC interference to the environment

This device produces high-frequency interference, which may make additional suppression measures necessary in domestic environments (☐ 8.1 "Electromagnetic compatibility (EMC)").

Please note the following on connecting the device:

1. Ensure that the mains supply provides the correct voltage and is suitable for the current required (see 7 "Technical data").
2. Ensure that suitable electrical fuses with the specified nominal current range are installed between the voltage source and the device.
3. Mains cable connection (supply – “LE”): on option slot **X1**
4. Motor cable connection (“MA”): on option slot **X3**
5. Optional
  - a. Mains cable connection (outlet – “LA”): on option slot **X2**, or
  - b. Motor cable connection (2. motor – “MA2”): on option slot **X2**

At least one four-core motor cable must be used and **U-V-W** and **PE** connected to the plug connector.



#### Information

##### Connection cables

Only use copper cables with temperature class 80°C or equivalent for connection. Higher temperature classes are permissible.

#### 2.3.2.1 Mains connection

No special fuses are required on the mains input side of the device. It is advisable to use mains fuses (see technical data) and a main switch or contactor.

Isolation from or connection to the mains must always be carried out synchronously and for all poles.

In the standard version, the device is configured for operation in TN or TT networks. The mains filter provides its normal effect and the resulting leakage current. A star point-earthed mains must be used.

In case of "Daisy Chain" wiring (looping of the mains voltage from one FI to the next) use of a fuse module type SK CU4-FUSE is recommended (☐ Section 1.3 "Scope of delivery"). This enables protection of the individual device. This avoids a total failure of the entire line in case of a device fault.

##### Adaptation to IT networks – (from size 1)

For operation in an IT network, the FI must be configured with modification of the integrated mains filter. Modification of the mains filter is performed at the factory and must be taken into account in the order. Configuration for IT networks reduces the EMC.

The insulation resistance of the frequency inverter must be taken into consideration when operating on an insulation monitor (☐ Section 7.1 "General motor starter data").

### 2.3.2.2 Motor cable (U, V, W, PE)

The motor cable must be connected properly.

Pre-assembled motor cables are available on request.

### 2.3.2.3 Electromechanical brake

For the control of an electromechanical brake, the device generates an output voltage provided at the motor plug's contacts (BR+ and BR-). The DC voltage level depends on the selected option. The following options can be selected:

“Integrated brake rectifier” option	Mains voltage (AC)	Brake coil voltage (DC)
-	-	No brake connection possible
HWR	400 V ~	180 V =
HWR	480 V ~	205 V =
BWRN <sup>1)</sup>	400 V ~	205 V =
BWRN <sup>1)</sup>	480 V ~	250 V =

1) Mains connection-side: N connection required!

The assignment of the correct brake or brake coil voltage must be taken into consideration in the design with regard to the device's mains voltage.



## Information

### Parameter P107/P114

When connecting an electromechanical brake to the respective terminals of the device, you need to adjust the parameters **P107** and **P114** (“Brake reaction time” and “Brake delay off”). Set value ≠ 0 in parameter **P107** to avoid damages in the brake control.

### 2.3.3 Electrical connection of the control unit

Connection of the control cables is made exclusively via M12 plug connectors. The plug connectors are permanently installed at the factory. These enable the use of straight connectors, and at option slots **M1** to **M8** angled (encapsulated) cable plug connectors. The use of cable plug connectors assembled by the customer must be checked in individual cases.

#### 24 V DC control voltage

The FI requires a 24 V DC control voltage for operation. Depending on the device, this control voltage can be provided in various ways:

- Integrated switched mains unit (equipment code **-HVS**),
- External connection via M12 plug connector (option slot **M8**),
- External connection via M12 plug connector (option slots **Z1 - Z4**),
- External connection via power plug connector (option slot **X1**).

Frequency inverters with the option **-HVS** typically do not require an external 24 V DC connection. If however such a device also has an optional 24 V DC connection facility, this can be used without danger. In this case the external 24 V DC supply supports the integrated switched mains unit. In particular this covers the requirements of powerful actuators which are controlled by the FI.

Devices which are not equipped with the **-HVS** option must be supplied via an external 24 V DC voltage source.

### Information

#### Control voltage overload

An overload of the control unit by impermissibly high currents may destroy it. Impermissibly high currents occur if the actual drawn total current exceeds the permissible total current.

24 V can be drawn from multiple terminals. This also includes e.g. digital outputs or a control module connected via RJ12.

The drawn total currents must not exceed the following limit values:

Device type	SK 155E	SK 175E
Device with integrated power supply unit ("HVS" device option) for SK 1x5E-FDS-...-ASI with "-AUX" option, even if the supply is exclusively via the yellow cable. Note: If additional control voltage is present, e.g. "-AUX" or "-AXS" option, the 530 mA and 490 mA currents may be drawn. It must, however, be ensured that the integrated power supply unit is not overloaded when there is no more external voltage.	380 mA	340 mA
Device without power supply unit (without "HVS" device option), external connection of control voltage for SK 1x5E-FDS-...-ASI with "-AUX" option, even if the supply is via the black and yellow cables. Note: For AS-i, applicable for "-AUX" or "-AXS" device option	530 mA	490 mA
Device without power supply unit ("-AS-i" or "-ASS" device option and without "HVS" device option) for SK 1x5E-FDS-...-ASI with "-ASI" option. The supply is exclusively effected via the yellow cable.	140 mA	100 mA

### Information

#### Response time of digital inputs

The response time to a digital signal is approx. 4 ... 5 ms and consists of the following:

Scan time	1 ms
Signal stability check	3 ms
Internal processing	< 1 ms

---

**i Information**

---

**Cable laying**

All control cables (including thermistors) must be routed separately from the mains and the motor cables to prevent interference in the device.



If the cables are routed in parallel, a minimum distance of 20 cm must be maintained from cables which carry a voltage of > 60 V. The minimum distance may be reduced by screening the cables which carry a voltage, or by the use of earthed metal partitions within the cable conduits.

Alternatively: Use a hybrid cable with shielding of the control lines.

---

### 2.3.3.1 Control connection details

Meaning, Functions	Description / Technical data		
Contact (designation)	Meaning	Parameter No.	Function of factory setting
<b>Digital outputs</b>	Signalling of the operating statuses of the FI		
	<b>according to EN 61131-2</b> 24 V DC With inductive loads: Provide protection via free-wheeling diode!	Maximum load 50 mA	
DOUT1	Digital output 1	P434 [-01]	No function
DOUT2	Digital output 2	P434 [-02]	No function
<b>Digital inputs</b>	Actuation of device using an external controller, switch or similar. The factory settings of digital inputs DIN1 to DIN3 depend on the configuration of option slots H1 and H2.		
	<b>DIN1-5 according to EN 61131-2, type 1</b> Low: 0-5 V (~ 9.5 kΩ) High: 15-30 V (~ 2.5 - 3.5 kΩ)	Scan time: 1 ms Reaction time: ≥ 4 ms Input capacitance: 10 nF	
DIN1	Digital input 1	P420 [-01]	No function
DIN2	Digital input 2	P420 [-02]	No function
DIN3	Digital input 3	P420 [-03]	No function
BDI1	Digital input 4	P420 [-09]	No function
BDI2	Digital input 5	P420 [-10]	No function
<b>PTC resistor input</b>	Monitoring of motor temperature using PTC		
	The motor's PTC resistor (TF) is connected via the motor connection. Use a shielded cable.	Connect a temperature sensor to put the device into operation mode. As an alternative, you can deactivate the input function. In this case, however, the thermal monitoring of the motor is no longer possible.	
TF+	PTC resistor input +	P425	On
TF-	PTC resistor input -		
<b>Control voltage source</b>	Control voltage from the inverter, e.g. as power supply for accessories		
	24 V DC ± 25 %, short circuit-proof	Maximum load <sup>1)</sup>	
VO / 24V	Voltage output	-	-
GND / 0V	Reference potential GND	-	-
1) See "Total currents" information (☞ Section 2.3.3 "Electrical connection of the control unit")			
<b>Control voltage connection</b>	Supply voltage for the device		
	24 V DC ± 25% 380 mA ... 800 mA, depending on the load on inputs and outputs and use of options <sup>1)</sup>	With option (-HVS): Automatic switching between external supply via plug-in connector and internal power supply unit if connected control voltage is insufficient.	
24 V	Input voltage	-	-
GND / 0V	Reference potential GND	-	-
1) If the frequency inverter's control unit is loaded with full power an external 24 V power supply unit has to be able to provide at least 800 mA See also the information regarding control voltage overload (☞ section 2.3.3 "Electrical connection of the control unit")			
<b>Brake actuation</b>	Connection and actuation of an electromechanical brake. The FI generates an output voltage for this, which depends on the mains voltage. The assignment of the correct brake coil voltage must be taken into account in the selection.		
	<b>Connected loads:</b> (☞ Section 2.3.2.3 "Electromechanical brake") Current: ≤ 500 mA	Permissible switching cycle time: to 150 Nm ≤ 1/s to 250 Nm ≤ 0.5/s	
BR+	Brake control	P107/114	0 / 0
BR-	Brake control		

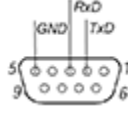
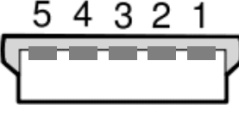
<b>AS Interface</b>		Control of FI via the simple field bus level: Actuator/sensor interface	
		Electrical data: See <a href="#">4.3.2</a> "Features and technical data"	
ASI+	ASI+	P480 ...	-
ASI-	ASI-	P483	-
<b>Communication interface</b>		Device connected to different communication tools	
		24 VDC ± 20%	RS 485 (For connecting a parametrisation box) 9600 ... 38400 Baud <i>Terminating resistance</i> (1 kΩ) fixed RS 232 (For connecting to a PC (NORD CON)) 9600 ... 38400 Baud
1	RS485 A+	Data cable RS485	 1 - 2 - 3 - 4 - 5 - 6
2	RS485 B-	Data cable RS485	
3	GND	Reference potential of bus signals	
4	RS232 TXD	Data cable RS232	
5	RS232 RXD	Data cable RS232	
6	+24 V	Voltage output	
<b>Connection cables (accessories / optional)</b>		Connection of the device to an MS-Windows® PC with NORDCON software	
		Length: approx. 3.0 m + approx. 0.5 m Part number: 275274604 Suitable for connection to a USB port in a PC or alternatively to a SUB-D9 connection. Details: <a href="#">TI 275274604</a>	 
<b>Communication interface</b>		Connection of the device to a PC (alternative to RJ12 interface) for communication with the NORDCON software	
		USB 2.0	RS 232 9600 ... 38400 Baud
1	+5V	Supply voltage	
2	Data -	Data cable	
3	Data +	Data cable	
4	GND	Bus signal reference potential	

### 3 Display, operation and options

#### **WARNING**

##### **Electric shock**

Touching the circuit board below the transparent screw cap on option slot **E1** can result in an electric shock which may cause serious or fatal injury.

- The screw cap for option slot **E1** must only be opened when the frequency inverter is switched off.
- After switching off the frequency inverter wait for at least 5 minutes before opening the screw cap.

---

The FI is equipped with LED indicator lights LED indicator lights are directly assigned to the option slots H1 and H2 as well as to M1 to M8. These are used to indicate the signal statuses of the relevant option slot. In addition, on option slot E1 there are further, externally visible LED indicator lights for status messages.

Alphanumeric display and control modules ( Section 3.2 "Control and parametrisation options ") can be used for simple commissioning by changing parameters. For more complex tasks, connection to a PC system can take place with the aid of the NORD CON parameterisation software.

Connection of such a parameterisation option is made via option slot D1. The screw cap must be removed for this. Communication is via RS 232 or RS 485 to an RJ12 connection (standard). Alternatively, a USB port can be installed as an alternative to the RJ12 connection. However, in this case it is only possible to connect a PC system for use of the NORDCON software.

Commissioning of the device is generally possible without parameter adaptation, i.e. without a parameterisation tool (NORDCON, ParameterBox, ControlBox). For this purpose, three potentiometers (P1 – P3) on option slot E2, and two 4-pole DIP switch blocks (S1 and S2) on option slot E1 are available.

For devices with an integrated interface for PROFIBUS DP (SK 1xxE-FDS-...-PBR), two additional 4-pole DIP switch blocks (S3 and S4) can be found on option slot E3. These are used for addressing.

#### **Information**

##### **Blind plug removal**

You can access the potentiometers and DIP switches by removing the blind plugs. Remove the blind plugs only for commissioning and replace them properly afterwards. Make sure that no moisture or dirt enters the device.

---

### 3.1 Displays

LED display version	Use/Meaning
Yellow <ul style="list-style-type: none"> <li>– single colour</li> <li>– static</li> </ul>	Indication of the signal status (“ON” / “OFF”) or the associated function of the IOs.
Red/Green <ul style="list-style-type: none"> <li>– single or dual colour</li> <li>– static or dynamic</li> </ul>	Indication of operating statuses on the inverter or communication level.

#### H1 and H2



- If **switching options** are used, the LEDs indicate the corresponding switch setting (left/right). If the switch is in centre position, the LEDs are off (**Yellow** colour)
- Option slot H2: If an illuminated pushbutton is installed here (optional), the LED signals for “Device status/Error” (see option slot E1) are also displayed via this button.

#### M1 to M8



- If **initiators or actuators** are used, the LEDs indicate the corresponding signal statuses (high/low). (**Yellow** colour)  
The options slots M1, M3, M5 and M7 are basically intended for double occupancy.
  - Lower LED: Signal status first input or output (e.g. DIN1)
  - Upper LED: Signal status second input or output (e.g. DIN2)
The options slots M2, M4, M6 and M8 are intended for single occupancy.
  - Lower LED: Signal status input or output (e.g. DIN2)
- If used for **bus communication via AS-Interface**, the LEDs of option slot M8 indicate the operational statuses of the corresponding slave.
  - Lower LED: A slave
  - Upper LED: B slave
(**Red/Green** colour, dual)
- The lower LED of option slot M5 indicates the status for the PROFIBUS on the device if **bus communication via PROFIBUS DP**, is used. (colour **green**)

#### E1



Option slot E1 is closed with a transparent screw cap. The LED status indicator lights which are installed in this option slot act as diagnostic LEDs and are therefore always visible.

- Device status/Error: The LED indicates the operating status of the FI. (colour **red / green**, dual)

#### 3.2 Control and parametrisation options

There are different control options available, installed on the option slots **H1** and **H2**. The required control options and their functions must be selected upon ordering or during the configuration process (📖 2.2.2.2 "Configuration of option slots of the control level"). Retrofitting is not possible.

Parameterisation units furthermore allow for an access to and the adjustment of the device's parametrisation.

Designation		Material No.	Comment
<b>Control and parameterisation units</b> (handheld)			
SK CSX-3H	SimpleBox	275281013	📖 <a href="#">BU 0040</a>
SK PAR-3H	ParameterBox	275281014	📖 <a href="#">BU 0040</a>
SK TIE5-BT-STICK	NORDAC ACCESS BT Bluetooth stick	275900120	📖 BU 0960

#### Connection

1. Remove the diagnostics glass of the RJ12 socket.
2. Establish RJ12-RJ12 cable connection between control unit and Motorstarter.

*As long as a diagnostics glass or a blind plug is open, make sure that no dirt or moisture enters the device.*

3. After commissioning for regular operation, **reinsert all diagnostics glasses or blind plugs** and pay attention to **sealing**.



#### Information

##### Diagnostic caps' tightening torques

The tightening torque for the transparent diagnostic caps (inspection glasses) is 2.5 Nm.

## 4 Commissioning

### **WARNING**

#### **Unexpected movement**

Connection of the supply voltage may directly or indirectly set the drive unit into motion. This may cause an unexpected movement of the drive unit and the connected machine. This unexpected movement may cause severe or fatal injuries and/or material damage.

Unexpected movements may be due to several causes, e.g.

- Parameterisation of an “automatic starting”,
- Incorrect parameterisation,
- Control of the device with an enabling signal from a higher level control unit (via IO or bus signals),
- Incorrect motor data,
- Release of a mechanical holding brake,
- External influences such as gravity or other kinetic energy which acts on the drive unit.

To avoid any resulting hazard, secure the drive or drive chain against unexpected movements (mechanical blocking and/or decoupling, provision of protection against falling, etc.). Ensure that there are no persons within the area of action and the danger area of the system.

### 4.1 Factory settings

All motor starters supplied by Getriebebau NORD are preprogrammed with the default setting for standard applications with 4-pole 3-phase standard motors (same voltage and power). The rated motor current (see, for example, motor name plate) can be set for the respective motor circuit via the DIP switch **S1**, which has priority in the factory settings or delivery state. If parameter **P130=1** is set, the rated motor current must be set in parameter **P203** “Motor current rating”.

### **Information**

#### **Hardware configuration**

Make sure that the hardware configuration is mechanically possible via the DIP switch blocks S1 and S2, the potentiometers P1 ... P3 or the adjustment of individual parameters. The decision is made by setting the parameter **P130** (see 4.2.2 "Configuration").

### 4.2 Starting up the device

The motor starter may be commissioned in various ways:

- a) For simple applications (e.g. conveyor applications) via the DIP switches and potentiometers accessible via the option slots **E1** – **E3**.
- b) By parameter adjustments via the control and parameterisation units (SK CSX-3H or SK PAR-3H), NORDAC *ACCESS BT* using the NORDCON *APP* or PC-based NORDCON software.

Pay attention to the setting of parameter **P130**. The parameter settings only take effect if **P130 = 1**.

After the **parameterisation** of the motor starter, the parameter values from the RAM memory **must be transferred to the device's flash memory (→ P550)**. Otherwise, the settings made will be lost upon shutdown of the device.

**Flash memory note: Approximately 100 memory cycles are possible.**

### 4.2.1 Connection

To establish basic operation capability, after the mechanical installation of the device on a suitable wall, the electrical connections must be made (see Section 2.3.2 "Electrical connection of power unit").

For devices without an integrated 24 V DC mains unit (option "integrated mains unit": "HVS") it is also essential for the FI to be provided with a 24 V DC control voltage.

### 4.2.2 Configuration

The device can be configured for the majority of operating modes by setting potentiometers (P1-P3) and DIP switches (S1, S2). For extended functions or for diagnostic purposes it may be necessary to adjust or view individual parameters.

The following lists the steps for commissioning the motor starter. First, it must be decided if commissioning shall take place via DIP switches and the potentiometers, or only via parameter settings.

The software adjustments made via the **parameters** are only **considered** if parameter **P130 = 1**.

All **parameters not listed** here **always have an influence** on the motor starter's function, irrespective of the parameter **P130** setting. With **P130 = 0**, they always remain in the factory setting.

Step		Commissioning via			
		Switch / Potentiometer (Hardware adjustment)		Parameter settings (Software adjustment)	
		Element	Default	Parameters	Default
1.	Parameter source	P130= 0	{ 0 }	P130= 1	{ 0 }
		P130= 2			
2.	Motor current rating	S1-DIP1...4	- <sup>1)</sup>	P203	{ 3 }
3.	Reverse lockout time	P1	- <sup>1)</sup>	P570	{ 0.5 }
4.	Initial voltage	P2	- <sup>1)</sup>	P210	{ 50 }
5.	Acceleration time	P3	- <sup>1)</sup>	P102	{ 1 }
6.	Expiration time			P103	{ 1 }
7.	Automatic starting	S2-DIP1	{ OFF }	P428	{ 0 }
8.	Motor overtemp. ( <b>SK 155E</b> )	S2-DIP2	{ OFF }	P580	{ 1 }
8.	Phase seq. check ( <b>SK 175E</b> )	S2-DIP2	{ OFF }	P581	{ 0 }
9.	Disconnection mode	S2-DIP3/4	{ OFF/OFF }	P108	{ 2 }
10.	Permanently save data			P550 = 1 <sup>2)</sup>	{ 0 }

1) For manufacturing reasons, no unique factory settings can be ensured.

2) After the software adjustments, the data must be transferred from the device's RAM memory to the flash memory to permanently store them. Otherwise, the data changes may be lost upon shutdown of the device.

**Table 4: Configuration – Comparison of hardware and software adjustments**



### Information

#### Permissible automatic reclosing cycle

Pay attention to the minimum pause times between two power-on procedures (see 8.4 "Switch-on cycle").

### 4.2.2.1 Parameterisation

The use of a control and parametrisation unit (SK CSX-3H/ SK PAR-3H), NORDAC ACCESS BT with the NORDCON APP or the NORDCON software is required to adjust the parameters. The following displays the most important parameters, depending on the setting of parameter **P130**:

Parameter group	Parameter numbers	Functions	Remarks
Basic parameter	P102 ... P103	Acceleration and expiration time	Factory setting: Potentiometer value <b>P3</b>
	P108	Disconnection mode	Factory setting: DIP switch value <b>S2-DIP3/4</b>
	P130	Parameter source <b>P130=0</b> → Pot/Switch <b>P130=1</b> → Flash memory	<b>P130=0</b> (factory setting): Potentiometer ( <b>P1-P3</b> ) and DIP switch ( <b>S1, S2</b> ) effective <b>P130=1</b> : Parameter settings effective
Motor data	P203	Motor current rating	Factory setting: <b>S1-DIP1...4</b> value
	P210	Initial voltage	Factory setting: Potentiometer value <b>P2</b>
Control terminals	P420, P434	Digital inputs and outputs	Factory setting: See parameter descriptions
Additional parameters	P570	Reverse lockout time	Factory setting: Potentiometer value <b>P1</b>

**Table 5: Parameters and functions depending on P130**

#### 4.2.2.2 Potentiometers P1 to P3

Using the potentiometers **P1** to **P3** (option slot **E2**), basic settings can be made for motor starter operation. They have a latching design and 10 scale values. The potentiometers have non-linear characteristic curves on the software side.

(For information on **S3** and **S4**, see  Section 4.4.3.4 "Addressing")

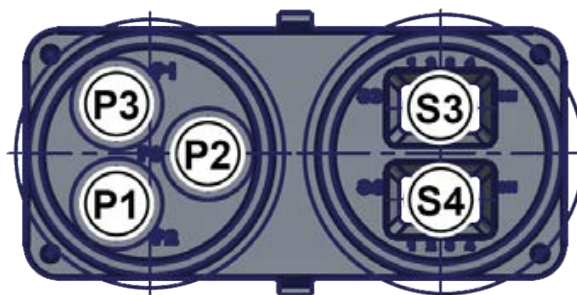

##### Potentiometer P1

→ Setting the reverse lockout time (see also **P570**)

Device type SK 175E-FDS-	Scale value [s]									
...301-...	0 <sup>1)</sup>	0.2	0.3	0.5	0.7	1.0	1.5	2.0	3.0	5.0

1) Without reverse lockout time

##### Potentiometer P2

→ Setting the initial torque (voltage) (see also **P210**)

Device type SK 1x5E-FDS-	Scale value [%]									
...301-...	10	15	20	25	30	35	40	50	70	100

##### Potentiometer P3

→ Setting the acceleration and expiration time (see also **P102/P103**)

Device type SK 1x5E-FDS-	Scale value [s]										
...301-...	OFF <sup>1)</sup>	0.1	0.2	0.3	0.5	0.7	1.0	1.5	2.0	3.0	

1) Soft start deactivated

### 4.2.2.3 DIP switch (S1, S2)

The rated motor current is set via the DIP switch (S1).

Basic functions of the motor starter are set via the DIP switch (S2).

The DIP switches are located at the option slot E1.



#### DIP switch (S1)

→ Setting the rated motor current

Device type SK 1x5E-FDS-	DIP switch position (Setting according to motor name plate)																
	0000	0001	0010	0011	0100	0101	0110	0111	1000	1001	1010	1011	1100	1101	1110	1111	
...111-...	OFF <sup>1)</sup>	0.3	0.4	0.5	0.6	0.7	0.8	0.9	1.0	1.2	1.4	1.6	1.9	2.2	2.5	2.9	[A]
...301-...	OFF <sup>1)</sup>	0.8	1.0	1.2	1.4	1.6	1.9	2.2	2.5	2.9	3.2	3.6	4.8	5.3	6.7	7.0	[A]

1) I<sup>2</sup>t-Monitoring deactivated

#### DIP switch (S2)

No.

Bit **DIP switch (S2)**

In delivery state, all four DIP switches are in position "0" ("OFF").

No. Bit	DIP switch (S2)	DIP no.		Description
		4	3	
4/3 2 <sup>3/2</sup>	<b>Shutdown mode</b>	0	0	Shutdown mode 1 (factory setting)
		1	0	Shutdown mode 2
		0	1	Shutdown mode 3
		1	1	Shutdown mode 4
2 2 <sup>1</sup>	<b>Overtemperature motor (SK 155E)</b>	0		Error message (E002) and shutdown of device in case of overtemperature
		1		Warning message (C002) in case of overtemperature (factory setting)
1 2 <sup>0</sup>	<b>Phase sequence detection (SK 175E)</b>	0		Phase sequence according to mains connection (factory setting)
		1		Phase sequence according to required direction of rotation → Automatic detection of phase sequence
1 2 <sup>0</sup>	<b>Automatic start</b>	0		Edge-controlled (factory setting)
		1		Level-controlled <b>ATTENTION: Drive may start up immediately!</b>

#### 4.2.2.4 Overview of disconnection modes

The disconnection mode determines the drive's acceleration and deceleration behaviour.

Parameter **P130** determines if the standstill or disconnection mode shall be set via hardware adjustments (DIP switch (**S1**, **S2**), potentiometer (**P1-P3**)) or via software adjustments (parameterisation **P108**).

The main behaviours can be set via hardware adjustments (factory setting).

In case of additional optimisation requirements, further settings via parameter adjustments are possible.

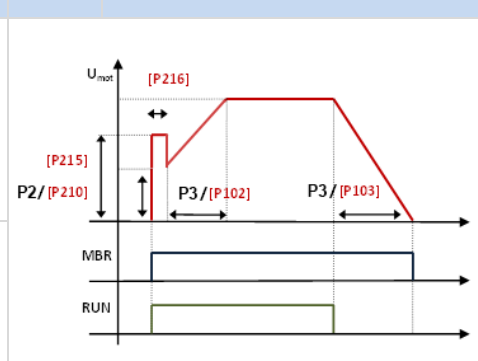
Switch-off mode 1		DIP3/4: OFF/OFF (Factory setting)	or	P108 = 0
Switch on (Set enable)	<ol style="list-style-type: none"> <li><b>P2</b> and <b>P210</b> determine the starting voltage (starting torque) that is applied to the motor.</li> <li>The brake opens.</li> <li><b>P3</b> and <b>P102</b> determine the duration for which the voltage is continuously increased until the full voltage (100 %) is reached.</li> </ol>			
Switch off (Cancellation of release)	<ol style="list-style-type: none"> <li><b>P3</b> and <b>P103</b> determine the duration for which the voltage is continuously reduced from 100 % to 0 %. <sup>1)</sup></li> <li>The brake is applied when the voltage reaches "0 %" or after <b>P107</b> has elapsed.</li> </ol>			

1) For technical reasons, the motor starter switches immediately to 0 % when approx. 10 % of the starting voltage is reached.

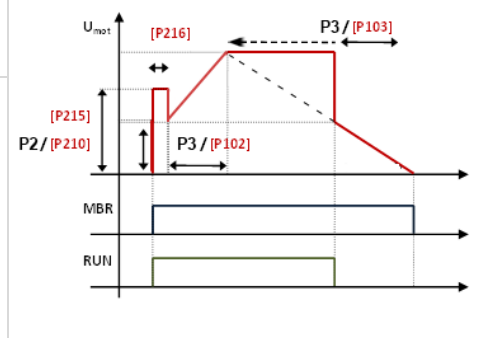
Switch-off mode 2		DIP3/4: OFF/ON	or	P108 = 1
Switch on (Set enable)	<ol style="list-style-type: none"> <li><b>P2</b> and <b>P210</b> determine the starting voltage (starting torque) that is applied to the motor.</li> <li>The brake opens.</li> <li><b>P3</b> and <b>P102</b> determine the duration for which the voltage is continuously increased until the full voltage (100 %) is reached.</li> </ol>			
Switch off (Cancellation of release)	<ol style="list-style-type: none"> <li><b>P2</b> and <b>P210</b> determine the voltage (torque) to which the motor controller immediately drops.</li> <li><b>P3</b> and <b>P103</b> determine the duration for which the voltage would be continuously reduced from 100 % to 0 %. However, only the part of the duration that is needed to reduce from the set starting voltage (<b>P2</b> or <b>P210</b>) to 0 % is used. <sup>1)</sup></li> <li>The brake is applied when the voltage reaches "0 %" or after <b>P107</b> has elapsed.</li> </ol>			

1) For technical reasons, the motor starter switches immediately to 0 % when approx. 10 % of the starting voltage is reached.

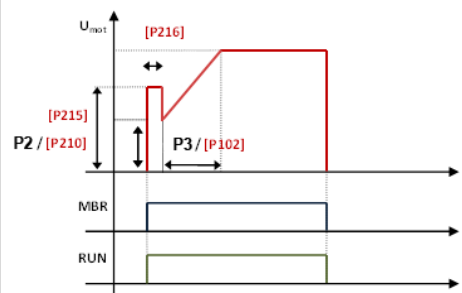
Switch-off mode 3		DIP3/4: ON/OFF	or	P108 = 2 (Factory setting)
Switch on (Set enable)	<ol style="list-style-type: none"> <li><b>P2</b> and <b>P210</b> determine the starting voltage (starting torque) that is applied to the motor.</li> <li>The brake opens.</li> <li><b>P3</b> and <b>P102</b> determine the duration for which the voltage is continuously increased until the full voltage (100 %) is reached.</li> </ol>			
Switch off (Cancellation of release)	<ol style="list-style-type: none"> <li>The motor is switched off immediately (voltage "0 %") and runs down to a standstill.</li> <li>The brake is applied when the voltage reaches "0 %" or after <b>P107</b> has elapsed.</li> </ol>			

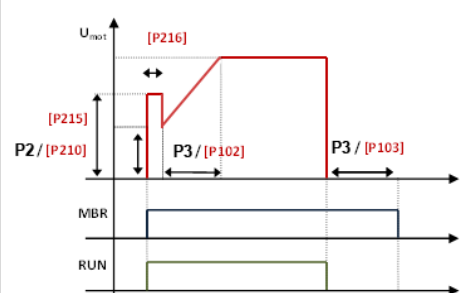
Switch-off mode 4		DIP3/4: ON/ON	or	P108 = 3
Switch on (Set enable)	<ol style="list-style-type: none"> <li><b>P2</b> and <b>P210</b> determine the starting voltage (starting torque) that is applied to the motor.</li> <li>The brake opens.</li> <li><b>P3</b> and <b>P102</b> determine the duration for which the voltage is continuously increased until the full voltage (100 %) is reached.</li> </ol>			
Switch off (Cancellation of release)	<ol style="list-style-type: none"> <li>The motor is switched off immediately (voltage "0 %") and runs down to a standstill.</li> <li><b>P3</b> and <b>P103</b> determine the duration of the delay, during which the brake is not yet applied.</li> <li>The brake is applied.</li> </ol>			

## 4.3 AS Interface (AS-i)

This section is only relevant for device of type SK 1xxE-FDS-...-ASI, SK 1xxE-FDS-AUX, SK 1xxE-FDS-AXS, SK 1xxE-FDS-ASS.

### 4.3.1 The bus system

#### General information

The **Actuator Sensor Interface (AS-Interface)** is a bus system for the lower field bus level. It has been defined in the AS-Interface *Complete Specification* and standardised according to EN 50295, IEC62026.

The transfer principle is a single-master system with cyclic polling. Since the *Complete Specification V2.1*, a maximum of **31 standard slaves** using the device profile **S-7.0.**, or **62 slaves in the extended addressing mode** using the device profile **S-7.A.** could have been operated with any network structure at an unshielded two-wire line up to 100 m long.

Doubling the number of possible slave participants is realised by the double assignment of the addresses 1-31 and the “A slave” or “B slave” labelling. Slaves in the extended addressing mode are labelled by the ID code A and can be clearly identified by the master.

Devices with slave profiles **S-7.0** and **S-7.A.** can be operated together within an AS-i network with version 2.1 and higher (**master profile M4**), considering the address assignment (see example).

Permissible	Not permissible
Standard slave 1 (address 6)	Standard slave 1 (address 6)
<b>A/B slave 1 (address 7A)</b>	<b>Standard slave 2 (address 7)</b>
<b>A/B slave 2 (address 7B)</b>	<b>A/B slave 1 (address 7B)</b>
Standard slave 2 (address 8)	Standard slave 3 (address 8)

Addressing is done via the master that also provides further management functions, or via a separate addressing unit.

#### Device-specific information

The transfer of the 4-bit application data (per direction) is performed with effective error protection for standard slaves with a maximum cycle time of 5 ms. Due to the higher number of participants, for slaves in the extended addressing mode, the cycle time is doubled (*max. 10 ms*) for data sent *from the slave to the master*. Extended addressing for sending data *to the slave* cause an additional doubling of the cycle time to *max. 21 ms*.

The AS-Interface cable (yellow) transfers data and power.

It can supply for both the total need of control voltage (including control voltage for the device and any connected sensors) and only the AS-Interface.

The supply of the device and any connected sensors can also be effected via an internal power supply unit (“-HVS” option), via the “black two-wire line” (only possible with plug connector option: “-AUX” or “-AXS” on option slot **M8**), or via a combination of both.

For the “-AUX” or “-AXS” option, the power supply unit (“-HVS” option) takes over a load-reducing power supply function. For the “-ASI” and “-ASS” options, it depends on the AS-i supply voltage level. Therefore, a load reduction cannot be assumed in each case.

“-AUX” or “-AXS” option (option slot **M8**): It is recommended, but not mandatory to effect the supply via **Protective Extra Low Voltage (PELV)**.

### 4.3.2 Features and technical data

The device can be directly integrated in an AS interface network is parametrised in its factory settings so that the most frequently used AS-i functionality is available immediately. Only adaptations for application-specific functions of the device or the bus system, the addressing and proper connection of the supply, BUS, sensor and actuator cables need to be carried out.

#### Features

- Electrically isolated bus interface
- Status display (LED)
- Configuration by parameterisation
- 24 V DC supply (integrated AS-i module and Motorstarter)

The following possibilities should be applied.

- a. Device with integrated power supply unit (device option “**-HVS**”) and connector option “**-ASI**” or “**-ASS**”
    - Connection via yellow cable for the supply of the AS-i module
    - Supply of the device and connected initiators or actuators via an integrated power supply unit

Note: If no mains voltage is present on the device, connected initiators are not visible for the AS-i master.
  - b. Device with integrated power supply unit (device option “**-HVS**”) and connector option “**-AUX**” or “**-AXS**”
    - Connection via yellow cable for the supply of the AS-i module
    - Connection via black cable for the supply of the device and the connected initiators

Note: If the black cable’s voltage falls below the voltage of the integrated power supply unit, the power supply unit takes over the device supply. If the black cable’s voltage falls below approx. 16 V DC, the integrated power supply unit also takes over the supply of the connected initiators or actuators.
  - c. Device without power supply unit (without device option “**-HVS**”) and with connector option “**-AUX**” or “**-AXS**”
    - Connection via yellow cable for the supply of the AS-i module
    - Connection via black cable for the supply of the device and the connected initiators or actuators
  - d. Device without power supply unit (without device option “**-HVS**”) and with connector option “**-ASI**” or “**-ASS**”
    - Connection via yellow cable for the supply of the AS-i module and the device

Note: This version causes a high current consumption for the AS-i cable and only offers low reserves for direct connection of initiators and actuators to the device.
- Connection to the device
    - Via M12 system plug connector at option slot **M8**

### Technical AS-Interface data

Designation	Option slot M8: Device with connector option ...			
	... “-ASI”	... “-ASS”	... “-AUX”	... “-AXS”
AS-i supply (yellow cable)	24 ... 31.6 V DC, ≤ 450 mA <sup>1)</sup>	24 ... 31.6 V DC, ≤ 450 mA <sup>1)</sup>	24 ... 31.6 V DC, ≤ 25 mA <sup>2)</sup>	
AUX supply (black cable)	<i>Connection not possible</i>		24 V DC ± 25%, ≤ 800 mA	
Slave profile	S-7.A	S-7.0	S-7.A	S-7.0
I/O code	7	7	7	7
ID code	A	0	A	0
Ext. ID code 1 / 2	7	F	7	F
Address	1A ... 31A and 1B ... 31B Delivery state: 0A	1 ... 31 Delivery state: 0	1A ... 31A and 1B ... 31B Delivery state: 0A	1 ... 31 Delivery state: 0
Cycle time	Slave → Master ≤ 10 ms Master → Slave ≤ 21 ms	≤ 5 ms	Slave → Master ≤ 10 ms Master → Slave ≤ 21 ms	≤ 5 ms
Number of application data (BUS I/O)	4I / 4O	4I / 4O	4I / 4O	4I / 4O
Extended required master	M4	M0, M1, M2, M3, M4	M4	M0, M1, M2, M3, M4

1) For supply exclusively via the yellow AS-i cable

2) For supply of the device and any connected sensors/actuators via the device's integrated power supply unit (“-HVS” option) and/or via the black cable.

### 4.3.3 Bus structure and topology

The AS-Interface network structure is optional (line, star, ring and tree structure) and is managed by an AS-Interface master as an interface between PLC and slaves. An existing network can be extended with further slaves up to a limit of 31 standard slaves or 62 slaves in the extended addressing mode. The addressing of slaves is done by the master or a respective addressing unit.

An AS-i master communicates independently and exchanges data with the connected AS-i slaves. No standard power supply units must be used in the AS-Interface network. For each AS-Interface line, only one special AS-Interface power supply unit may be used for voltage supply. This AS-Interface voltage supply is connected directly to the yellow standard cable (AS-i(+)) and AS-i(-) cable) and should be positioned as close as possible to the AS-i master to keep the voltage drop low.

To avoid interferences, the **PE connection of the AS-Interface power supply unit** (if available) **must be earthed**.

The brown **AS-i(+)** and the blue **AS-i(-)** wire of the yellow AS-Interface cable **must not be earthed**.

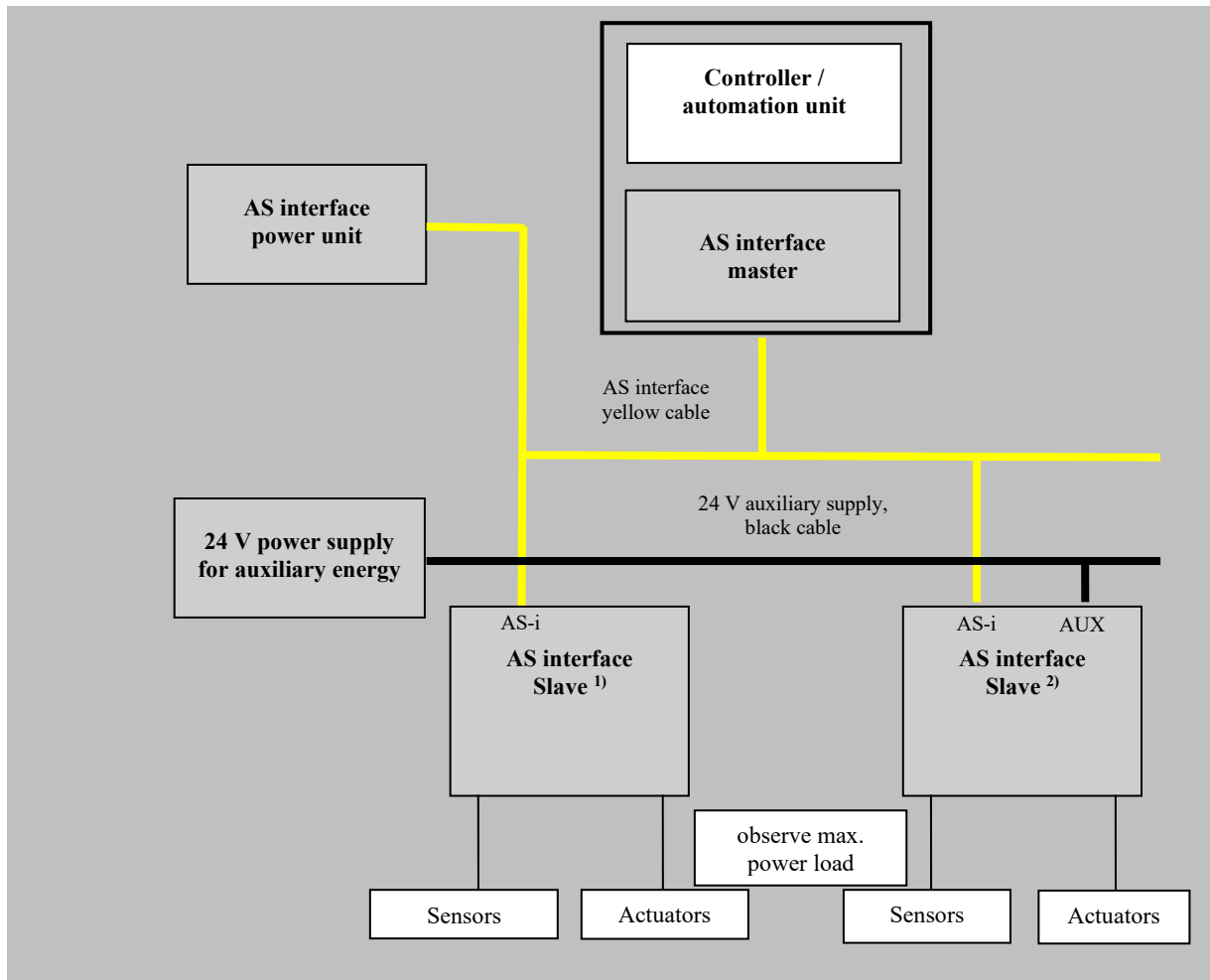

1)	SK 1xxE-FDS-...ASI- with "-ASI" or "-ASS" plug connector <sup>a)</sup>
2)	SK 1xxE-FDS-...ASI- with "-AUX" <sup>a)</sup> or "-AXS" <sup>a)</sup> plug connector

a) With or without integrated power supply unit ("-HVS" option)

## 4.3.4 Commissioning

### 4.3.4.1 Connection

1. The connection of the AS-Interface cable (yellow) is established via the “-ASI”, “-AUX”, “-AXS” or “-ASS” plug connector on option slot **M8**.
2. The connection of a two-wire line to supply with auxiliary power (“black cable”) is established via the “-AUX” or “-AXS” plug connector on option slot **M8** (only if available). The supply should preferably be effected via PELV.

(📖 Section 2.3.3.1 "Control connection details")

### 4.3.4.2 Displays

The status of the AS interface is signalled by a multi-colour **AS-i** LED.



AS-i LED	Meaning
OFF	<ul style="list-style-type: none"> <li>• No AS interface voltage to the module</li> <li>• Connections not connected or exchanged</li> </ul>
green ON	<ul style="list-style-type: none"> <li>• Normal operation (AS interface active)</li> </ul>
red ON	<ul style="list-style-type: none"> <li>• No exchange of data <ul style="list-style-type: none"> <li>– Slave address = 0 (slave still in factory setting)</li> <li>– Slave not in LPS (list of planned slaves)</li> <li>– Slave with incorrect IO/ID</li> <li>– Master in STOP mode</li> <li>– Reset active</li> </ul> </li> </ul>
Alternately flashing red / green Flashing (2 Hz) <sup>1)</sup>	<ul style="list-style-type: none"> <li>• Peripheral error <ul style="list-style-type: none"> <li>– Control unit in device not starting (AS-i voltage too low or control unit defective)</li> </ul> </li> </ul>

1) Switch-on frequency per second, example: 2 Hz = LED 2 x second "On"

### 4.3.4.3 Configuration

The most important functionality is assigned via the arrays [-05] ... [-08] of parameter (P420) and via the arrays [-04] ... [-05] of parameter (P434).

#### Bus I/O bits



#### Unexpected movement due to automatic starting

In the event of a fault (communication interrupted or bus cable disconnection) the device automatically switches off, since the device enable is no longer present.

Restoration of communication may result in an automatic start and therefore unexpected movement of the drive unit. To prevent any hazard, a possible automatic start must be prevented as follows:

- If a communication error occurs, the bus master must actively set the control bits to “zero”.

The device is equipped with two additional digital inputs for connecting initiators. However, there are no optional outputs for connecting actuators which are operated directly via the BUS. The following connections are each provided for four reference data bits:

BUS-IN	Function (P420[-05...-08])
Bit 0	Enable right
Bit 1	Enable left
Bit 2	Acknowledge fault <sup>1)</sup>
Bit 3	Release brake manually <sup>2)</sup>

- 1) Acknowledge with flank 0 → 1.  
For control via the bus, acknowledgement is not automatically performed by a flank on one of the enable inputs
- 2) 0 = Brake applied, will be released automatically if required  
1 = Brake is released immediately.

Status		Status
Bit 1	Bit 0	
0	0	Motor is switched off
0	1	Field of rotation right present at motor
1	0	Field of rotation left present at motor
1	1	Motor is switched off

BUS-OUT	Function (P434 [-04 ... -05])
Bit 0	Fault (status bit 0)
Bit 1	Operation (status bit 1)
Bit 2 <sup>1)</sup>	Initiator 1 status (BDI1)
Bit 3 <sup>1)</sup>	Initiator 2 status (BDI2)

- 1) Bits 2 and 3 are directly coupled to digital inputs BDI1 and BDI2.

Status		Status
Bit 1	Bit 0	
0	0	Error active
0	1	Standby (motor stationary)
1	0	Warning (but motor running)
1	1	Run (motor running without warning)



## Information

## Error number output

Alternatively, the error number can also be transferred via the AS-i Out Bits 0 and 1. To do this, in **AS-i Master Parameter bit 1** (0-3) must be changed from the standard setting. As a result, the **motor starter** transfers the **BUS-OUT Bit 0** and then the **Strobe-Signal** to the **BUS-OUT Bit 1** and the **Count-Signal**. The Strobe signal is a cyclical signal, which marks the start of a new transfer cycle. The Count signal outputs the error number from the number of High flanks between each Strobe signal.

Example:

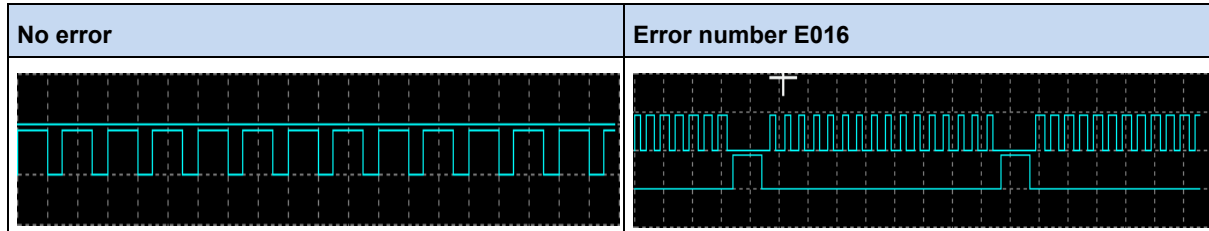

**Note:** The bottom line shows the Strobe signal (Bit 0); the top line shows the Count signal (Bit 1).

Parallel actuation via the BUS and the digital inputs (BDI1, BDI2) is possible. The relevant inputs are dealt with more or less as normal digital inputs. If a changeover between manual and automatic is going to take place, it must be ensured that no enable via the normal digital inputs takes place in automatic mode. This could be implemented e.g. with a three-position key switch. Position 1: "Manual left" Position 2: "Automatic" Position 3: "Manual right".

If an enable is present via one of the two "normal" digital inputs, the control bits from the bus system are ignored. An exception is the control bit "Acknowledge fault". This function is always possible in parallel, regardless of the control hierarchy. The bus master can therefore only take over control if no actuation via a digital input takes place. If "Enable left" and "Enable right" are set simultaneously, the enable is removed and the motor stops without a deceleration ramp (block voltage).



## Information

## Manual / Automatic mode

If a digital output is parameterised to the function "Disable automatic operation" (see **P420**) the following must be noted for the implementation of the example above: Switch Control Element 1 (Switch **H1**) to manual mode. The programmed enabling direction can be selected with switch **H2**.

### 4.3.4.4 Addressing

In order to use the device in an AS-i network, it must have a unique address. The address is set to 0 in the factory. This means that the device can be recognised as a "new device" by an AS-i master (prerequisite for automatic address assignment by the master).

#### **Course of action**

- Ensure power supply of the AS interface via the yellow AS interface cable.
- Disconnect the AS interface master during addressing
- Set the address  $\neq 0$
- Do not doubly assign addresses

In many other cases, addressing is carried out using a normal addressing device for AS interface slaves (example follows).

- Pepperl+Fuchs, VBP-HH1-V3.0-V1 (separate M12 connection for external power supply)
- IFM, AC1154 (battery operated addressing device)



#### **Information**

Special conditions for the supply exclusively via the yellow cable

- Ensure voltage supply of the **SK 1xxE-FDS-...-ASI, SK 1xxE-FDS-AUX, SK 1xxE-FDS-AXS, SK 1xxE-FDS-ASS** device also via yellow AS-Interface cable (pay attention to current consumption of control level of the device's **SK 1xxE-FDS-...-ASI, SK 1xxE-FDS-ASS** control level (450 mA))
- When using an addressing unit
  - Do not use the internal voltage source of the addressing unit
  - Battery-operated addressing units do not supply the required current and are therefore not suitable
  - Use addressing units with a separate 24 V DC connection for external voltage supply (example: Pepperl+Fuchs, VBP-HH1-V3.0-V1)

The following lists options how to practically implement the addressing of the AS-i slave using an addressing unit.

### Version 1

Using an addressing device which is equipped with an **M12 connector** for connecting to the **AS-i bus**, you can incorporate yourself into a the AS interface network via an appropriate access. The prerequisite for this is that the AS interface master can be switched off.

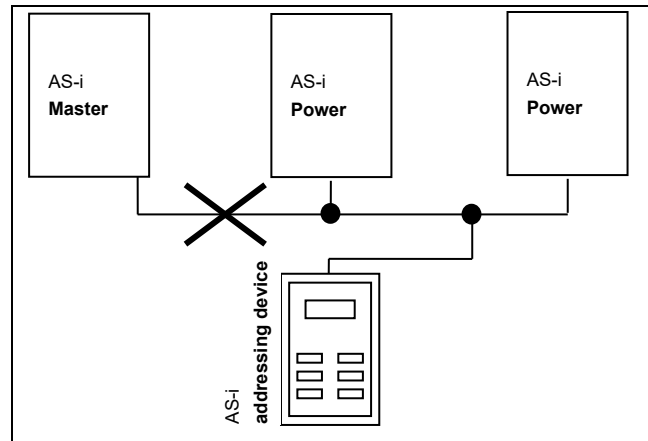

### Version 2

With an addressing device that is equipped with an **M12 connector** for connecting to the **AS-i bus** and an additional **M12 connector** for connecting an external **voltage supply**, the addressing device can be directly incorporated in the AS-i cable.

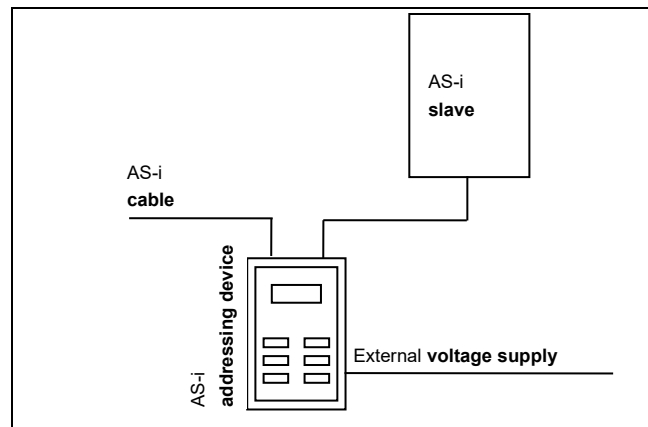

### 4.3.5 Certificate

Currently available certificates can be found on the Internet at [Link "www.nord.com"](http://www.nord.com)

### 4.4 PROFIBUS DP

This section is only relevant for device of type **SK 1x5E-FDS-...-PBR**.

#### 4.4.1 The bus system

PLC's, PC's, operating devices and monitoring devices can all communicate via a uniform bus in serial bit mode using PROFIBUS DP. PROFIBUS DP is preferably used where time-critical rapid and complex communication between individual devices is required. The bus system is suitable as a substitute for cost-intensive parallel 24 V DC signal transfer of process data.

PROFIBUS communication is specified in the international standards IEC 61158 and IEC 61784. Application and planning aspects are specified and documented in the guidelines of the PROFIBUS users' organisation (PNO). This ensures that devices from different manufacturers can communicate with each other. The data exchange is specified in DIN 19245 parts 1 and 2 and application-specific extensions in part 3 of this standard. As part of the European field bus standardisation process, PROFIBUS is being integrated into the European field bus standard EN 50170.

#### 4.4.2 Features

- Electrically isolated bus interface
- Status display (1 LED)
- Address setting via DIP switch **S3** and **S4** (option slot **E3**)
- Optional termination resistor as M12 plug connector for Profibus output (M7): 275130076
- Transmission of 4 control bits and 4 status bits
- Supports sync and freeze modes of the PROFIBUS DP communication function
- Watchdog function; in case of a fault, all bits of the setpoint PDO are set to 0
- No parameter communication
- Baud rate up to 12 Mbit/s
- Connection to the device
  - Via M12 system plug connector

### 4.4.3 Commissioning

#### 4.4.3.1 Connection

The PROFIBUS cable (purple) is made via the plug connector **PBR (Bus-In)** on option slot **M5** or **PBR (Bus-Out)** on option slot **M7**.

#### 4.4.3.2 Displays

The status of the PROFIBUS is signalled by a **BR** LED.

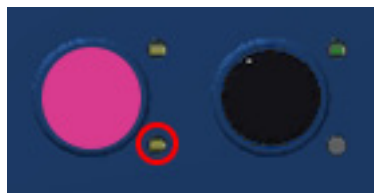

LED BR	Meaning
OFF	<p>No cyclic process data communication active, i.e. no data communication with slave.</p> <ul style="list-style-type: none"> <li>• PLC / Master in STOP or switched off</li> <li>• Missing 24 V DC voltage supply to motor starter</li> <li>• Profibus cable between PLC / Master and motor starter / Slave not connected</li> <li>• Connections not connected or exchanged</li> <li>• Bus terminating resistor not set correctly (at first and last slave of bus line)</li> <li>• Erroneous addressing (wrong address set)</li> <li>• Missing hardware configuration in PLC / Master, possible wrong GSD file (NORD0DA5.gsd) used (<a href="#">Link</a>)</li> </ul>
green ON	<ul style="list-style-type: none"> <li>• Normal operation (cyclic process data communication in operation)</li> </ul>

#### 4.4.3.3 Configuration

##### Process data

The process data is used to control the motor starter and communicate its status. The transfer of this data is carried out cyclically. There is only one process data object (PDO) for the motor starter, with a fixed data length of 1 byte. Only the bottom 4 bits are used. A distinction is made between the setpoint PDO (from PLC to device (BUS-IN bits)) and the actual value PDO (from device to PLC (BUS-OUT bit)).

### Bus I/O bits

#### WARNING

#### Unexpected movement due to automatic starting

In the event of a fault (communication interrupted or bus cable disconnection) the device automatically switches off, since the device enable is no longer present.

Restoration of communication may result in an automatic start and therefore unexpected movement of the drive unit. To prevent any hazard, a possible automatic start must be prevented as follows:

- If a communication error occurs, the bus master must actively set the control bits to "zero".

The device is equipped with two additional digital inputs for connecting initiators. However, there are no optional outputs for connecting actuators which are operated directly via the BUS. The following connections are each provided for four reference data bits:

BUS-IN	Function (P420[-05...-08])	Status		Status
		Bit 1	Bit 0	
Bit 0	Enable right	0	0	Motor is switched off
Bit 1	Enable left	0	1	Field of rotation right present at motor
Bit 2	Acknowledge fault <sup>1)</sup>	1	0	Field of rotation left present at motor
Bit 3	Release brake manually <sup>2)</sup>	1	1	Motor is switched off

- 1) Acknowledge with flank 0 → 1.  
For control via the bus, acknowledgement is not automatically performed by a flank on one of the enable inputs
- 2) 0 = Brake applied, will be released automatically if required  
1 = Brake is released immediately.

BUS-OUT	Function (P434 [-04 ... -05])	Status		Status
		Bit 1	Bit 0	
Bit 0	Fault (status bit 0)	0	0	Error active
Bit 1	Operation (status bit 1)	0	1	Standby (motor stationary)
Bit 2 <sup>1)</sup>	Initiator 1 status (BDI1)	1	0	Warning (but motor running)
Bit 3 <sup>1)</sup>	Initiator 2 status (BDI2)	1	1	Run (motor running without warning)

- 1) Bits 2 and 3 are directly coupled to digital inputs BDI1 and BDI2.

Parallel actuation via the BUS and the digital inputs (BDI1, BDI2) is possible. The relevant inputs are dealt with more or less as normal digital inputs. If a changeover between manual and automatic is going to take place, it must be ensured that no enable via the normal digital inputs takes place in automatic mode. This could be implemented e.g. with a three-position key switch. Position 1: "Manual left" Position 2: "Automatic" Position 3: "Manual right".

If an enable is present via one of the two "normal" digital inputs, the control bits from the bus system are ignored. An exception is the control bit "Acknowledge fault". This function is always possible in parallel, regardless of the control hierarchy. The bus master can therefore only take over control if no actuation via a digital input takes place. If "Enable left" and "Enable right" are set simultaneously, the enable is removed and the motor stops without a deceleration ramp (block voltage).

#### 4.4.3.4 Addressing

The motor starter is addressed via two 4-pole DIP switch blocks (**S3/ S4**). They can be found on option slot **E3**.

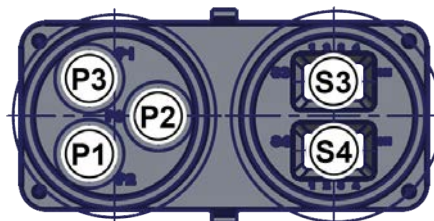

##### “S4” switch (x1)

- Setting the decimal number range from 0 to 9

##### “S3” switch (x10)

- Setting the address's 10s digit. The 0 to 9 setting range is linked to the factor 10.

##### Example

Switch **S3** = 4 (0100) (→ **4x**)

Switch **S4** = 2 (0010) (→ **x2**)

→ Resulting PROFIBUS address = **42**

DIP switch encoding

S3 or S4	Value
0000	0
0001	1
0010	2
0011	3
0100	4
0101	5
0110	6
0111	7
1000	8
1001	9
1010	/ <sup>1)</sup>
...	
1111	

1) No function

The motor starter's PROFIBUS address can be set via the DIP switches in the ranges from 1 to 79 and 81 to 99.

If the **addresses 0 or 80** are set, the motor starter interprets these values as address 126. **Communication is not possible.**

The address is read directly after switching on the 24 V supply at the motor starter.

A **change of address** becomes effective only **after switching on the 24 V DC** voltage supply of the device again.

## 5 Parameter

### WARNING

#### Unexpected movement

Connection of the supply voltage may directly or indirectly set the drive unit into motion. This may cause an unexpected movement of the drive unit and the connected machine. This unexpected movement may cause severe or fatal injuries and/or material damage.

Unexpected movements may be due to several causes, e.g.

- Parameterisation of an “automatic starting”,
- Incorrect parameterisation,
- Control of the device with an enabling signal from a higher level control unit (via IO or bus signals),
- Incorrect motor data,
- Release of a mechanical holding brake,
- External influences such as gravity or other kinetic energy which acts on the drive unit.

To avoid any resulting hazard, secure the drive or drive chain against unexpected movements (mechanical blocking and/or decoupling, provision of protection against falling, etc.). Ensure that there are no persons within the area of action and the danger area of the system.

### WARNING

#### Unexpected movement due to changes in the parameterisation

Parameter changes become effective immediately. Under certain conditions, dangerous situations may occur, even when the drive is in standstill. Functions such as **P428** “Automatic starting” or **P420** “Digit inputs” or the “Brake off” setting can put the drive in motion and put persons at risk due to moving parts.

Therefore:

- Changes to parameter settings must only be made when the Motorstarter is not enabled.
- During parametrisation works, precautions must be taken to prevent unwanted drive movements (e.g. lifting equipment plunging down). The danger area of the system must not be entered.

The relevant parameters for the device are described in the following. The parameters are accessed using a parametrisation tool (e.g. NORDCON software or control and parametrisation unit, see also  Section 3.2 “Control and parametrisation options”) and therefore makes it possible to adapt the device to the drive task in the best possible way. Different device configurations can result in dependencies for the relevant parameters.

The parameters can only be accessed if the control unit of the device is active.

Depending on the device configuration, the control voltage can be supplied via an optional plug connector. As an alternative, the device may be equipped with a power supply unit (option: “-HVS”) that generates the required 24 V DC control voltage by applying the mains voltage (see 2.3.2 “Electrical connection of power unit”).

Connections and any priority circuits with the potentiometers (**P1...**) and the DIP switches (**S1** and **S2**) are described at the suitable positions and must be considered (**P130**).

Parameter changes have an immediate effect on the RAM memory only and are therefore volatile, To secure these changes, a copy order (**P550**) must be triggered after the parameter adjustment. This transfers the data to the permanent memory (flash memory) of the device.

## Information

The ParameterBox SK PAR-3H must have at least software version 4.6 R1.

The individual parameters are functionally combined in groups. The first digit of the parameter number indicates the assignment to a **menu group**:

Menu group	No.	Master function
<b>Operating displays</b>	(P0--)	Display of parameters and operating values
<b>Basic parameters</b>	(P1--)	Basic device settings, e.g. on/off switching behaviour
<b>Motor data</b>	(P2--)	Electrical settings for the motor (motor current or starting voltage (starting voltage))
<b>Speed control</b>	(P3--)	Settings for the integrated PLC
<b>Control terminals</b>	(P4--)	Assignment of functions for the inputs and outputs
<b>Additional parameters</b>	(P5--)	Priority monitoring function and other parameters
<b>Information</b>	(P7--)	Display of operating values and status messages

## Information

### Factory setting P523

Use the parameter **P523** to load the factory setting of the entire parameter set. The restoration of the factory settings (**P523**) affects all parameters. Check the motor data afterwards and readjust them if needed.

Furthermore, the potentiometers (P1-P3) and the DIP switch (S1, S2) are reactivated.

## 5.1 Parameter overview

### Operating displays

<b>P000</b> Operating para. disp	<b>P001</b> Select of disp.value	<b>P003</b> Supervisor-Code
----------------------------------	----------------------------------	-----------------------------

### Basic parameters

<b>P102</b> Acceleration time	<b>P103</b> Expiration time	<b>P107</b> Brake reaction time
<b>P108</b> Disconnection mode	<b>P114</b> Brake delay off	<b>P130</b> Parameter source
<b>P131</b> Phase control mode		

### Motor data

<b>P203</b> Motor current rating	<b>P210</b> Initial voltage	<b>P215</b> Boost voltage
<b>P216</b> Boost time		

### Control parameters

<b>P350</b> PLC functionality	<b>P351</b> PLC set val. select.	<b>P353</b> Bus status via PLC
<b>P555</b> PLC Integer setvalue	<b>P356</b> PLC long setvalue	<b>P360</b> PLC display value
<b>P370</b> PLC status		

### Control terminals

<b>P400</b> Analog input func.	<b>P420</b> Digit inputs	<b>P427</b> Quick stop on Error
<b>P428</b> Automatic starting	<b>P434</b> Digital output	<b>P499</b> Func. DIP switches

### Additional parameters

<b>P523</b> Factory setting	<b>P535</b> I <sup>2</sup> t motor	<b>P536</b> Current limit
<b>P538</b> Check input voltage	<b>P539</b> Check output voltage	<b>P550</b> Copy Flash Memory
<b>P553</b> PLC set values	<b>P570</b> Reverse lockout time	<b>P580</b> Overtemp. error
<b>P581</b> Phase seq. check	<b>P582</b> Brake man Release	

### Information

<b>P700</b> Current operating state	<b>P707</b> Software-Version	<b>P708</b> State of digital in.
<b>P709</b> State potentiometer	<b>P711</b> State of digital out	<b>P716</b> Current frequency
<b>P718</b> Mains frequency	<b>P719</b> Actual current	<b>P720</b> Act.Current
<b>P721</b> Re.Current	<b>P722</b> Current voltage	<b>P723</b> Voltage -d
<b>P724</b> Voltage -q	<b>P725</b> Current cos phi	<b>P726</b> Apparent power
<b>P727</b> Mechanical Power	<b>P728</b> Line voltage	<b>P732</b> Phase U current
<b>P733</b> Phase V current	<b>P734</b> Phase W current	<b>P740</b> PZD bus in
<b>P741</b> PZD bus out	<b>P743</b> Device type	<b>P744</b> Configuration
<b>P749</b> Status Dip-switches	<b>P752</b> Err changeover relay	<b>P753</b> Err bypass relay
<b>P762</b> Voltage Phase U	<b>P763</b> Voltage Phase V	<b>P764</b> Voltage Phase W
<b>P780</b> Device ID		

## 5.2 Description of parameters

### 5.2.1 Explanation of parameter description

P000 (parameter number)	Operating para. disp. (parameter name)	xx <sup>1)</sup>	S	P
<b>Setting range</b> (or display range)	Representation of typical display format (e.g. (bin = binary) of possible setting range and number of decimal places	<b>Other applicable parameter(s):</b>	List of other directly related parameters	
<b>Arrays</b>	[-01] If parameters have a substructure in several arrays, this is shown here.			
<b>Factory setting</b>	{ 0 } Typical default setting of parameters in the as-delivered condition of the FI, or to which it is set after carrying out "Restore factory settings" (see parameter P523).			
<b>Scope of application</b>	List of variants for which this parameter applies. If the parameter is generally valid, i.e. for the entire model series, this line is omitted.			
<b>Description</b>	Description, function, meaning and similar for this parameter.			
<b>Note</b>	Additional notes about this parameter			
<b>Setting values</b> (or display values)	List of possible settings with description of their respective functions			

1) xx = Other codes

### Information

Unused lines of information are not listed.

*Note / Explanation:*

Code	Designation	Meaning
<b>S</b>	Supervisor-Parameter	The parameter can now be displayed and modified if the relevant supervisor code has been set (see parameter <b>P003</b> ).
<b>P</b>	Parameter set-dependent	The parameter provides different setting options that are dependent upon the selected parameter set.
<b>RD</b>	READ	Parameter can only be read.
<b>RM</b>	RAM	The parameter can be modified but not stored in the Flash memory.
<b>RF</b>	READ/FLASH	According to the setting of parameter <b>P130</b> , the parameter can either only be read or can be changed and saved in the flash memory.
<b>FL</b>	FLASH	The parameter is read out of the flash memory and can be changed.

**5.2.2 Operating displays**

<b>P001</b>		<b>Selection of display value</b>		<b>RM</b>
<b>Setting range</b>	0 ... 11	Other applicable parameter(s): <b>P000</b>		
<b>Factory setting</b>	{ 0 }			
<b>Description</b>	Selection of the operating value to be displayed (see <b>P000</b> )			
<b>Setting values</b>	<b>Value</b>	<b>Meaning</b>		
	0	Actual frequency [Hz]	Output frequency currently being supplied by device	
	1	Nominal frequency [Hz]	Frequency of mains voltage that is currently present	
	2	Current [A]	Current output current measured by device	
	3	Effective current [A]	Effective current currently being supplied by device	
	4	Reactive current [A]	Reactive current currently being supplied by device	
	5	Mains voltage [V]	Voltage currently being measured at the input terminals	
	6	cos Phi [-]	Calculated value of current power factor	
	7	Apparent power KVA	Calculated value of current apparent power	
	8	Effective power [kW]	Calculated value of current effective power	
	9	Mains phase sequence [-]	0 = Clockwise rotating field 1 = Counter-Clockwise rotating field	
	10	Duty factor [%]	Phase angle control value currently being achieved by device. 0 % = "Motor off", 100 % = "Motor voltage = Mains voltage"	
	11	Actual current amplification [%]	Actual measured current in relation to the measurement range	

<b>P003</b>		<b>Supervisor code</b>		<b>RM</b>
<b>Setting range</b>	0 ... 9999			
<b>Factory setting</b>	{ 0 }			
<b>Description</b>	The scope of the visible parameters can be influenced by setting the supervisor code.			
<b>Setting values</b>	<b>Value</b>	<b>Meaning</b>		
	0	Supervisor mode off	The supervisor parameters are not visible.	
	1	Supervisor mode on	All parameters are visible.	
	2 ...	Supervisor mode off	The supervisor parameters are not visible.	

### 5.2.3 Basic parameters

<b>P102</b>	<b>Acceleration time</b>	<b>RF</b>
<b>Setting range</b>	0.00 ... 3.00 s	Other applicable parameter(s): <b>P130, P216</b>
<b>Factory setting</b>	{ 1.00 }	
<b>Description</b>	The acceleration time is the time that the drive needs to reach the maximum speed after receiving the enable. Since the acceleration time is determined by the phase control variation, it is only a case of indirect control of the acceleration time here. The actual acceleration time of the motor essentially depends on the motor which is used, the inertial masses and the counter-torque.	
<b>Note</b>	<p>As long as parameter <b>P130=0</b> is set, the acceleration time is determined via potentiometer <b>P3</b>. In this case the parameter can only be read, but not changed. It then corresponds to the setting determined by the potentiometer.</p> <p>If the motor is idling or in the case of drives with extremely low counter-torque, the soft start should be selected. Because the inertial masses and the counter-torque are disproportional, the phase control procedure cannot control the drive properly. The drive unit and its surroundings may be subjected to unwanted mechanical loads (vibration or the like).</p>	
<b>P103</b>	<b>Run-down time</b>	<b>RF</b>
<b>Setting range</b>	0.00 ... 3.00 s	Other applicable parameter(s): <b>P107, P108, P130</b>
<b>Factory setting</b>	{ 1.00 }	
<b>Description</b>	The run-down time is the time that the drive needs to reach a speed of "0" after the enable has been removed. Since the run-down time is determined by the phase control variation, it is only a case of indirect control of the run-down time here. The actual run-down time of the motor essentially depends on the motor which is used, the inertial masses and the counter-torque.	
<b>Note</b>	<p>As long as parameter <b>P130=0</b> is set, the run-down time is determined via potentiometer <b>P3</b>. In this case the parameter can only be read, but not changed. It then corresponds to the setting determined by the potentiometer.</p> <p>If the motor is idling or in the case of drives with extremely low counter-torque, the soft start should be selected. Because the inertial masses and the counter-torque are disproportional, the phase control procedure cannot control the drive properly. The drive unit and its surroundings may be subjected to unwanted mechanical loads (vibration or the like).</p>	
<b>P107</b>	<b>Brake reaction time</b>	<b>FL</b>
<b>Setting range</b>	0.00 ... 3.00 s	Other applicable parameter(s) <b>P103, P108</b>
<b>Factory setting</b>	{ 0.00 }	
<b>Description</b>	<p>Time delay for the application (closing) of an electro-magnetic brake after the run-down time has been reached (<b>P103</b>) or the enable removed.</p> <p>Once the motor starter has blocked its voltage at the output, a connected mechanical brake remains open until the time set in <b>P107</b> has elapsed. This allows the motor to reduce its speed or even stop before the brake is applied.</p>	
<b>Note</b>	<p>In switch off mode 4 (DIP switch S2-DIP3/4) the application time of the brake is determined by parameter <b>P103</b>/Potentiometer P3.</p> <p>Depending on the reaction time of the brake, the motor can be expected to switch off before the brake is applied. For lifting equipment applications, this means that there is a risk of the load dropping at the time of stopping.</p>	

P108	Switch-off mode		RF
Setting range	0 ... 3	Other applicable parameter(s): P103, P107, P130, P210	
Factory setting	{ 2 }		
Description	This parameter determines the reaction of the motor starter on the removal of the enable.		
Note	As long as parameter P130=0 is set, switch-off mode is determined via the DIP switch S2-DIP3/4. In this case the parameter can only be read, but not changed. It then corresponds to the setting that is determined by the DIP switch. (📖 Section 4.2.2.4 "Overview of disconnection modes")		
Setting values	Value	Meaning	
	0	Switch-off mode 1	The phase control becomes continuous, increased from 0 to 100% within the time period in accordance with P103 or potentiometer P3 (voltage drops). The brake is then applied in accordance with the time specified by P107 or P3.
	1	Switch-off mode 2	The phase control becomes continuous, increased from a start value (Y) to 100% within a time period (X) (voltage drops). The start value (Y) is determined by P210 or potentiometer P2. The time period (X) is determined by P103 or potentiometer P3, whereby the starting point of the time axis is shifted to the theoretical start value (Y=0 %). The brake is then applied in accordance with the time specified by P107 or P3.
	2	Switch-off mode 3	The output voltage is shut off immediately and the brake is applied when the voltage reaches "0 %" or after P107 has elapsed.
	3	Switch-off mode 4	The output voltage is shut off immediately and the brake is applied in accordance with the time specified by P103 or P3.

P114	Brake release time		FL
Setting range	0.00 ... 3.00 s		
Factory setting	{ 0.05 }		
Description	Setting of the time delay for enabling the motor after switch on.		
Note	Electromagnetic brakes have a delayed reaction time for their release, which depends on physical factors. If the brake release time set in parameter P114 is too long the motor operates against the brake, which is still applied. This can result in a start-up current that is too high, which will make the starter shut off with an overcurrent error.		

P130	Parameter source		FL
Setting range	0 ... 1	Other applicable parameter(s) P550	
Factory setting	{ 0 }		
Description	Selection of whether the DIP switches (S1, S2) and potentiometers (P1-P3) have priority over the parameter setting.		
Note	<ul style="list-style-type: none"> <li>Switch-over of P130 from setting 1 → 0: The RAM memory is deleted, parameter settings which have not been transferred to the flash memory (P550) are lost.</li> <li>Switch-over of P130 from setting 0 → 1: The default values of the parameter are used. To adopt parameter values from the flash memory the FI must be restarted (note the wait time between two mains switch on cycles! (📖 Section) 7 "Technical data").</li> </ul>		
Setting values	Value	Meaning	
	0	Potentiometer/Switch	All parameters which are marked "RF" can only be read but cannot be changed. These are determined by (S1, S2) and (P1-P3).
	1	Flash memory	All settings at the device are determined by the parameters. (S1, S2) and (P1-P3) have no influence.
	2	Potentiometer switch + flash	As for setting "0" However, the functions of the digital inputs and outputs are determined via the parameters (P420 or P434).

P131	Phase control mode		FL
<b>Setting range</b>	0 ... 1		
<b>Factory setting</b>	{ 0 }		
<b>Description</b>	Adaptation of the operating behaviour (running characteristics) of the motor		
Setting values	Value	Meaning	
	0	Current-optimised	Optimisation of phase control for an even current flow. This reduces the losses in the motor when starting up, but leads to an increased tendency to oscillate in the event of long ramps and an idling motor.
	1	Oscillation-optimised	Optimisation of phase control for reduced tendency to oscillate with idling motors or long ramps.

## 5.2.4 Motor data

P203	Rated motor current		RF
<b>Setting range</b>	0.50 ... 18.80 A	Other applicable parameter(s) <b>P130</b>	
<b>Factory setting</b>	{ 3.00 }		
<b>Description</b>	The rated motor current is needed for I <sup>2</sup> t monitoring. For normal applications, the setting corresponds to the nominal current as per the motor type plate.		
<b>Note</b>	As long as parameter <b>P130</b> =0 is set, the rated motor current is determined via the DIP switch <b>S1-DIP1...4</b> . In this case the parameter can only be read, but not changed. It then corresponds to the setting that is determined by the DIP switch.		

P210	Start voltage		RF
<b>Setting range</b>	10.0 ... 100.0 %	Other applicable parameter(s): <b>P108, P130</b>	
<b>Factory setting</b>	{ 50.0 }		
<b>Description</b>	The start voltage is the voltage that the device supplies immediately after setting the enable at the motor terminals.		
<b>Note</b>	As long as parameter <b>P130</b> =0 is set, the rated motor current is determined via potentiometer <b>P2</b> . In this case the parameter can only be read, but not changed. It then corresponds to the setting determined by the potentiometer.		
<b>Setting values</b>	100.0 = the soft start is disabled.		

P215	Boost voltage		FL
<b>Setting range</b>	0.0 ... 100.0 %	Other applicable parameter(s): <b>P210, P216</b>	
<b>Factory setting</b>	{ 0.0 }		
<b>Description</b>	The boost voltage determines a boost to the start voltage in the starting phase. The required breakaway torque is therefore provided for drives with increased starting torque.		
<b>Note</b>	The boost voltage time is limited by <b>P216</b> .		

P216	Time boost		FL
<b>Setting range</b>	0.00 ... 3.00 s	Other applicable parameter(s): <b>P102, P215</b>	
<b>Factory setting</b>	{ 0.00 }		
<b>Description</b>	<b>P216</b> defines the time limit of the boost voltage ( <b>P215</b> ) or the increased starting torque.		
<b>Note</b>	The resulting acceleration time ( $T_{total}$ ), which achieved until full control of the voltage, is calculated accordingly as: $T_{total} = T_{P102} + T_{P216}$ .		

**5.2.5 Speed control**

<b>P350</b>	<b>PLC functionality</b>		<b>FL</b>
<b>Setting range</b>	0 ... 1	Other applicable parameter(s) <b>P351</b>	
<b>Factory setting</b>	{ 0 }		
<b>Description</b>	Activation of the integrated PLC		
<b>Setting values</b>	<b>Value</b>	<b>Meaning</b>	
	0	Off	The PLC is not active, control of the device is via IOs or switch options (see option slot <b>H1 / H2</b> )
	1	On	The PLC is active, device is actuated via the PLC, depending on <b>P351</b> .
<b>P351</b>	<b>PLC setpoint selection</b>		<b>FL</b>
<b>Setting range</b>	0 ... 1	Other applicable parameter(s) <b>P350, P553</b>	
<b>Factory setting</b>	{ 0 }		
<b>Description</b>	Selection of the source for the control word ( <b>P553</b> ) and main setpoint with active PLC functionality ( <b>P350 = 1</b> ). This parameter is only adopted if the frequency inverter is in "Ready to start" status.		
<b>Setting values</b>	<b>Value</b>	<b>Meaning</b>	
	0	STW = PLC	The PLC provides the control word
	1	STW = Invalid	The control word from the PLC is invalid
<b>P353</b>	<b>Bus status via PLC</b>		<b>FL</b>
<b>Setting range</b>	0 ... 1	Other applicable parameter(s) <b>P350</b>	
<b>Factory setting</b>	{ 0 }		
<b>Description</b>	Selects how the status word from the device is to be processed by the PLC.		
<b>Setting values</b>	<b>Value</b>	<b>Meaning</b>	
	0	Off	The control word (STW) and the status word (ZSW) are processed by the PLC without change.
	1	Status word (ZSW) for the bus	The status word (ZSW) of the device is set by the PLC. In order to do this, the status word must be redefined in the PLC using process value "28_PLC_status_word".
<b>P355</b>	<b>PLC integer setpoint</b>		<b>FL</b>
<b>Setting range</b>	-32768 ... 32767		
<b>Arrays</b>	[-01] ... [-10]		
<b>Factory setting</b>	All Arrays: { 0 }		
<b>Description</b>	Data can be exchanged with the PLC via this INT array. This data can be used by the appropriate process variables in the PLC.		
<b>P356</b>	<b>PLC long setpoint</b>		<b>FL</b>
<b>Setting range</b>	-2 147 483 648 ... 2 147 483 647		
<b>Arrays</b>	[-01] ... [-05]		
<b>Factory setting</b>	All Arrays: { 0 }		
<b>Description</b>	Data can be exchanged with the PLC via this DINT array. This data can be used by the appropriate process variables in the PLC.		
<b>P360</b>	<b>PLC display value</b>		<b>RD</b>
<b>Display range</b>	- 2 147 483.648 ... 2 147 483.647		
<b>Arrays</b>	[-01] ... [-05]		
<b>Description</b>	Display of PLC data. By means of the relevant process variables, the parameter arrays can be written by the PLC. The values are not saved!		

P370	PLC status		RD
<b>Display range</b>	0000 ... FFFF <small>(hex)</small>	0000 0000 ... 1111 1111 <small>(bin)</small>	
<b>Description</b>	Display of the actual PLC status.		
<b>Display values</b>	<b>Value (Bit)</b>	<b>Meaning</b>	
	0	P350=1	<b>P350</b> has been set to the function "Activate internal PLC".
	1	PLC active	The internal PLC is active
	2	Stop active	The PLC program is set to "Stop"
	3	Debug active	Debugging of the PLC program is running.
	4	PLC error	The PLC has an error. However, PLC user errors 23.xx are not displayed here.
	5	PLC stopped	The PLC program has been stopped (single step or breakpoint)
	6	Scope Memory in use	A function block uses the memory area for the oscilloscope function of the NORDCON software. The oscilloscope function cannot be used.

## 5.2.6 Control terminals

P400	Function Analogue input		RD
<b>Display range</b>	0 ... 6	Other applicable parameter(s) <b>P102, P103, P130, P203, P210, P570</b>	
<b>Arrays</b>	[-01] = Function Analogue input 1 (= value for P203 from DIP switch S1) [-02] = Function Analogue input 2 (= value for P570 from potentiometer P1) [-03] = Function Analogue input 3 (= value for P210 from potentiometer P2) [-04] = Function Analogue input 4 (= value for P102 / 103 from potentiometer P3)		
<b>Description</b>	Display of the function of the relevant DIP switch <b>S1</b> or potentiometer <b>P1 ... P3</b> , if the DIP switch or the relevant potentiometer is active.		
<b>Note</b>	If <b>P130=1</b> is set, all DIP switches and potentiometers are disabled. "0" = "No function" is displayed in all arrays.		
<b>Display values</b>	<b>Value</b>	<b>Meaning</b>	
	0	No function	The DIP switch or potentiometer is not used.
	1	Rated motor current	The DIP switch supplies the value for <b>P203</b>
	2	Locking time	The potentiometer supplies the value for <b>P570</b>
	3	Starting torque	The potentiometer supplies the value for <b>P210</b>
	4	Ramp times	The potentiometer supplies the value for <b>P102 / P103</b>
	5 ...	<i>reserved</i>	

P420	Digital inputs	RF
<b>Setting range</b>	0 ... 13	Other applicable parameter(s) <b>P130, P428</b>
<b>Arrays</b>	[-01] = Digital input 1 (= value for digital input DIN1) [-02] = Digital input 2 (= value for digital input DIN2) [-03] = Digital input 3 (= value for digital input DIN3) [-04] = PTC input (= value for PTC input TF) [-05] = Bus In bit 0 (= value for Bus In bit 0) [-...] ... [-08] = Bus In bit 3 (= value for Bus In bit 3) [-09] = Bus digital input 1 (= value for bus digital input BD11) [-10] = Bus digital input 2 (= value for bus digital input BD12)	
<b>Factory setting</b>	{ [-01] = * }                      { [-02] = * }                      { [-03] = * }                      { [-04] = 8 } { [-05] = 1 }                      { [-06] = 2 }                      { [-07] = 7 }                      { [-08] = 9 } { [-09] = 0 }                      { [-10] = 0 } *) The factory settings of the arrays [-01] ... [-03] depend on the control elements which are used (configuration of option slots <b>S1</b> and <b>S2</b> ), see  Section 2.2.2.2 "Configuration of option slots of the control level"	
<b>Description</b>	Assignment of functions for the various digital inputs.	
<b>Note</b>	In order to change parameter values, <b>P130=1</b> must be set. Otherwise the settings of <b>P420</b> can only be read. Non-permissible settings are ineffective and are not saved.	
<b>Setting values</b>	<b>Value</b>	<b>Meaning</b>
	0	No function
	1	Enable right
	2	Enable left
	3	Enable right via bus
	4	Enable left via bus
	5	Disable voltage ( <b>coast to stop</b> )
	6	Emergency stop
	7	Fault acknowledgement
	8	PTC input
	9	Release the brake
	10	Automatic mode disabled <sup>2)</sup>
	11	Block enable right
	12	Block enable left
	13	PLC stop

- 1) If, depending on parameter **P130**, Dip switch 2 (**S2**) or parameter **P428** is parameterised to "Automatic start", no flank is required. A "High Level" is sufficient.
- 2) If a digital input is parameterised to this function, the device cannot be enabled with "Enable right" or "Enable left" in automatic mode. For this the device must first be switched to "Manual mode".

P427		Emerg. stop Fault		FL
Setting range	0 ... 1	Other applicable parameter(s): P108, P130, P428		
Factory setting	{ 0 }			
Description	<i>Emergency stop fault</i> - decision as to how the motor starter should react in the event of an error.			
Setting values	Value	Meaning		
	0	Off	An error leads to immediate motor starter shut-off (motor runs down to a standstill and brake, if present, is applied immediately)	
	1	On	With errors <b>E2.0</b> , <b>E3.0</b> , <b>E5.1</b> , <b>E6.1</b> the drive is run down in the selected switch-off mode before the motor starter shuts off with an error message.	

P428		Automatic starting		RF
Setting range	0 ... 1	Other applicable parameter(s): P130, P428		
Factory setting	{ 0 }			
Description	Decision as to whether the motor starter should react to an enable signal.			
Note	As long as parameter <b>P130=0</b> is set, the automatic start-up is determined via DIP switch <b>S2-DIP1</b> . In this case the parameter can only be read, but not changed. It then corresponds to the setting that is determined by the DIP switch.			
Setting values	Value	Meaning		
	0	Off	The device expects a flank (signal change "low → high") at the digital input which has been parametrised to "Enable" in order to start the drive. If the device is switched on with an active enable signal (mains voltage on), it immediately switches to "Switch-on inhibit".	
	1	On	The device expects a signal level ("high") at the digital input which has been parametrised to "Enable" in order to start the drive. <b>NOTICE! Risk of injury! Drive starts up immediately!</b>	

<b>P434</b>	<b>Digital out function</b>		<b>RF</b>
<b>Setting range</b>	0 ... 21	Other applicable parameter(s): <b>P130</b>	
<b>Arrays</b>	[-01] = Digital out 1 (= Value for digital output DO1) [-02] = Digital out 2 (= Value for digital output DO2) [-03] = Mechanical Brake (= Value for mechanical brake MB) [-04] = Bus Out Bit 0 (= Value for Bus Out Bit 0) [-05] = Bus Out Bit 1 (= Value for Bus Out Bit 1)		
<b>Factory setting</b>	{ [-01] = 1 }	{ [-02] = 2 }	{ [-03] = 3 }
	{ [-04] = 1 }	{ [-05] = 2 }	
<b>Description</b>	Assignment of functions for the various digital outputs.		
<b>Note</b>	Set <b>P130=1</b> to change the parameter values. Otherwise, the settings of <b>P434</b> can only be read.  Impermissible settings are invalid and are not saved.  The parameterisation of Array [-03] cannot be changed.		
<b>Setting values</b>	<b>Value</b>	<b>Meaning</b>	
	0	No function	Output not used.
	1	Error / Warning	Error or warning is active.
	2	Motor running	The drive is running.
	3	Mechanical Brake	A mechanical brake is controlled. „High signal“ = Brake releases
	4	Status dig in 1	Display of signal status of digital input 1
	5	Status dig in 2	Display of signal status of digital input 2
	6	Status bus dig in 1	Display of signal status from digital input 1 via bus <sup>1)</sup>
	7	Status bus dig in 2	Display of signal status from digital input 2 via bus <sup>1)</sup>
	8	Status bus dig in 3	Display of signal status from digital input 3 via bus <sup>1)</sup>
	9	Status bus dig in 4	Display of signal status from digital input 4 via bus <sup>1)</sup>
	10	State man./auto	Display of operating state: Manual/automatic mode (= 0 / 1)
	11	Status dig in 3	Display of signal status of digital input 3
	12	PLC output Bit0	Display of signal status of output 1 of PLC
	13	PLC output Bit1	Display of signal status of output 2 of PLC
	...	...	...
	19	PLC output Bit7	Display of signal status of output 8 of PLC
	20	Output via PLC	The output is set by the integrated PLC
	21	Fault or manual mode	There is a fault, or manual mode is active. (The function is Low - Active.)

<sup>1)</sup> Only SK 175E via integrated AS-Interface or PROFIBUS DP

<b>P499</b>	<b>Function DIP switch</b>		<b>RD</b>
<b>Display range</b>	0 ... 6	Other applicable parameter(s): <b>P108, P130, P428, P570</b>	
<b>Arrays</b>	[-01] = Function DIP switch 1 (= value for P428) [-02] = Function DIP switch 2 (= value for P581) [-03] = Function DIP switch 3 (= value for P108 (bit 0)) [-04] = Function DIP switch 4 (= value for P108 (bit 1))		
<b>Description</b>	Display of functions of DIP switch ( <b>S2</b> ).		
<b>Note</b>	If <b>P130=1</b> is set, all DIP switches are inactive. "0" = "No function" is displayed in all arrays.		
<b>Display values</b>	<b>Value</b>	<b>Meaning</b>	
	0	No function	The DIP switch is not used
	1	Automatic starting	The DIP switch supplies the value for <b>P428</b>
	2	Phase sequence detection	The DIP switch supplies the value for <b>P581</b>
	3 - 4	<i>reserved</i>	
	5	Switch-off mode bit 0	The DIP switch supplies the value for <b>P108</b> – bit 0
	6	Switch-off mode bit 1	The DIP switch supplies the value for <b>P108</b> – bit 1

## 5.2.7 Additional parameters

P523	Factory setting		RM
<b>Setting range</b>	0 ... 1	Other applicable parameter(s): <b>P550</b>	
<b>Factory setting</b>	{ 0 }		
<b>Description</b>	Reset all motor start parameters to the factory settings.		
<b>Note</b>	The setting is not permanent until the values from the RAM have been transferred to the Flash memory (see <b>P550</b> ).		
<b>Setting values</b>	<b>Value</b>	<b>Meaning</b>	
	0	No change	This function is not implemented.
	1	Load factory setting	All parameters are reset to the factory settings. The display then jumps back to a value of "0".

P535	I <sup>2</sup> t motor		FL
<b>Setting range</b>	0 ... 2	Other applicable parameter(s): <b>P108, P203, P427</b>	
<b>Factory setting</b>	{ 1 }		
<b>Description</b>	<i>I<sup>2</sup>t motor shut-off class</i> – This determines how quickly the motor starter shuts off in the event of overcurrent. The rated current upon which the I <sup>2</sup> t monitoring is based is determined by <b>P203</b> . The shut-off takes place almost immediately as of 7.2 times the rated current. (Error <b>E3.0</b> )		
<b>Note</b>	The three selectable motor shut-off classes are based on curves that are defined in EN 60947-4-2.		
<b>Setting values</b>	<b>Value</b>	<b>Meaning</b>	
	0	Class 5	1.5x overcurrent for 60 s / 9 s <sup>1)</sup>
	1 <sup>2)</sup>	Class 10A	1.5x overcurrent for 85 s / 12 s <sup>1)</sup>
	2	Class 10	1.5x overcurrent for 170 s / 24 s <sup>1)</sup>

- 1) 1. Value: cold motor  
2. Value: warm motor with 100% load
- 2) Class 10A only for rated motor current ≤ 4 A

Detailed information:  Section 8.3 "Trigger classes (I<sup>2</sup>t)"

P536	Current limit		FL
<b>Setting range</b>	80 ... 401 %	Other applicable parameter(s) <b>P203</b>	
<b>Factory setting</b>	{ 401 }		
<b>Description</b>	Limitation of the starting current relative to the rated motor current ( <b>P203</b> ). If the current limit is exceeded the starting ramp is extended until the current limit is undershot.		
<b>Setting values</b>	401 % = The function is switched off		

<b>P538</b>	<b>Check input voltage</b>		<b>FL</b>
<b>Setting range</b>	0 ... 3	Other applicable parameter(s): <b>P108, P427</b>	
<b>Factory setting</b>	{ 3 }		
<b>Description</b>	<i>Check input voltage</i> – Selection of variants for mains monitoring (terminals L1-L2-L3) by the device.		
<b>Note</b>	For reliable operation of the device, the voltage supply must have a certain quality. If there is an interruption of a phase or the voltage supply exceeds a specific limit value, the device will issue a fault.		
	Monitoring must only be deactivated if other (external) measures ensure that the starter is switched off in case of a mains fault.		
<b>Setting values</b>	<b>Value</b>	<b>Meaning</b>	
	0	Switched off	No monitoring of the supply voltage.
	1	Phase error	Phase errors lead to error message ( <b>E7.0</b> )
	2	Mains voltage	Overvoltage and undervoltage in the supply network lead to an error message ( <b>E5.1, E6.1</b> )
	3	Phase err. + mains voltage	Combination of settings 1 and 2. → Phase errors or mains errors lead to an error message ( <b>E5.1, E6.1, E7.0</b> )

<b>P539</b>	<b>Output monitoring</b>		<b>FL</b>
<b>Setting range</b>	0 ... 3	Other applicable parameter(s): <b>P203</b>	
<b>Factory setting</b>	{ 3 }		
<b>Description</b>	Selection of output monitoring variant (terminals U-V-W) by the device.		
<b>Setting values</b>	<b>Value</b>	<b>Meaning</b>	
	0	Mechanic. Brake	Overcurrent and short circuit of the brake rectifier result in error message <b>E4.5</b> , e.g. in case of defective electromechanical brake.
	1	MBrake + motorphases	Combination of settings 0 and 5: Phase and brake rectifier faults result in error message <b>E16.0</b> or <b>E4.5</b> .
	2	Mbrake+Magnetisation	Combination of settings 0 and 6: Brake rectifier and magnetisation faults result in error message <b>E16.1</b> or <b>E4.5</b> .
	3	MBR+Motorph.+Magnet.	Combination of settings 0, 5 and 6: Phase, brake rectifier and magnetisation faults result in error message <b>E016</b> or <b>E004</b> .
	4	Switched off	No monitoring of output voltage
	5	Motor Phases only	Phase faults (asymmetries of the measured output current) result in error message <b>E16.0</b> .
	6	Magnetisation only	If, in normal operation (after the acceleration time), the measured output current is less than 20% of the motor current rating ( <b>P203</b> or DIP switch <b>S1</b> ), this results in error message <b>E16.0</b> .
	7	Motor Phas.+Magnet.	Combination of settings 5 and 6: Phase and magnetisation faults result in error message <b>E16.0</b> .

<b>P550</b>	<b>Flash copy order</b>		<b>RM</b>
<b>Setting range</b>	0 ... 1		
<b>Factory setting</b>	{ 0 }		
<b>Description</b>	Transfer the modified parameter settings to the (non-volatile) Flash memory of the device.		
<b>Note</b>	Parameter changes initially only affect the volatile RAM memory, and are lost when the device is switched off. In order to retain the parameter changes permanently, they must be transferred to the Flash memory. A maximum of 100 copy processes can be guaranteed.		
<b>Setting values</b>	<b>Value</b>	<b>Meaning</b>	
	0	No change	This function is not implemented.
	1	RAM -> Flash	Copying process starts. The device then carries out an automatic "RESET". Parameter <b>P550</b> is reset to "0".

P553		PLC setpoints		FL
<b>Setting range</b>	0 ... 12	Other applicable parameter(s) <b>P350, P351</b>		
<b>Arrays</b>	[-01] = PLC-In Bit 1: [-...] ... [-08] = PLC-In Bit 8:			
<b>Factory setting</b>	All Arrays: { 0 }			
<b>Description</b>	Assignment of functions for the various PLC control bits.			
<b>Setting values</b>	<b>Value</b>	<b>Meaning</b>		
	0	No function	The input is not used.	
	1	Enable right	The drive runs with a right-hand direction of rotation.	High active Flank 0 → 1 <sup>1)</sup>
	2	Enable left	The drive runs with a left-hand direction of rotation.	High active Flank 0 → 1 <sup>1)</sup>
	3	Enable right via bus	The drive runs with a right-hand direction of rotation.	High active Flank 0 → 1 <sup>1)</sup>
	4	Enable left via bus	The drive runs with a left-hand direction of rotation.	High active Flank 0 → 1 <sup>1)</sup>
	5	Disable voltage ( <b>coast to stop</b> )	Drive runs down to a standstill.	Low active
	6	Emergency stop	Drive switches to "Switch-on block" after switching off (termination of selected switch-off mode).	Low active
	7	Fault acknowledgement	Acknowledge fault message. Acknowledgement only possible if the cause of the message is no longer present.	Flank 0 → 1
	8	PTC input	For evaluating a PTC signal.	High active
	9	Release the brake	The brake is released manually (signal "high") or automatically (signal "low")	High active
	10	Automatic mode disabled	Remote control disabled, control only via digital IOs of the device.	High active
	11	Enable right blocked	Direction of rotation right is blocked.	High active
	12	Block enable left	Direction of rotation left is blocked.	High active

1) If, depending on parameter **P130**, DIP switch 2 (**S2**) or parameter **P428** is parameterised to "Automatic start", no flank is required. A "High Level" is sufficient.

P570		Locking time		RF
<b>Setting range</b>	0 ... 25.00 s	Other applicable parameter(s): <b>P102, P103, P108, P130</b>		
<b>Factory setting</b>	{ 0.50 }			
<b>Description</b>	The locking time determines the period of time during which the motor is not powered after the end of the run-down time and before the acceleration time started in the event of a change of rotating direction (reversing).			
<b>Note</b>	<p>As long as parameter <b>P130=0</b> is set, the locking time is determined via potentiometer <b>P1</b>. In this case the parameter can only be read, but not changed. It then corresponds to the setting determined by the potentiometer.</p> <p>If the locking time is insufficient, the motor may still be rotating at the end of the run-down time. Starting in the opposite direction of rotation would result in the motor being subjected to excessive loads (thermal, mechanical) because of the counter-current braking that occurs as a result.</p>			

P580	Error in the event of overtemp.		RF
Setting range	0 ... 1	Other applicable parameter(s): P108, P427	
Factory setting	{ 1 }		
Description	<i>Fault shut-off due to overtemperature</i> – selection of whether an over temperature error (PTC) should lead to a warning or a fault shut-off.		
Setting values	Value		Meaning
	0	Off	Warning (C002) due to overtemperature
	1	On	Fault message (E002) and shut-off of device due to overtemperature
P581	Phase sequence detection		RF
Setting range	0 ... 1	Other applicable parameter(s): P130, P428	
Factory setting	{ 0 }		
Description	Analysis of phase sequence of supply network by the device and automatic adaptation of rotary field of motor to the required direction of rotation.		
Note	As long as parameter P130=0 is set, phase sequence detection is determined via the DIP switch S2-DIP2. In this case the parameter can only be read, but not changed. It then corresponds to the setting that is determined by the DIP switch.		
Setting values	Value		Meaning
	0	Off	The direction of rotation of the motor is determined by the direction of rotation of the supply network.
	1	On	The direction of rotation of the motor is determined by the enable direction.
P582	Manual brake release		RF
Setting range	0 ... 1	Other applicable parameter(s): P420	
Factory setting	{ 0 }		
Description	Definition of conditions for releasing a connected electro-mechanical brake		
Note	<b>DANGER!</b> With certain drive tasks (e.g. lifting gear) it can be dangerous to release of the brake without the drive running (risk of raised load falling)!		
Setting values	Value		Meaning
	0	Off	The brake is only released if the motor is enabled.
	1	On	The brake is released even if the motor has not been enabled (e.g. if a drive is to be moved for revision work). → Pay attention to note!

## 5.2.8 Information

<b>P700</b>	<b>Current operating status</b>		<b>RD</b>
<b>Display range</b>	0.0 ... 25.4		
<b>Arrays</b>	[-01] = Current error	Current active error message (not acknowledged)	
	[-02] = Current warning	Current existing warning	
	[-03] = Reason for switch-on block	Current existing reason for an active switch-on block	
<b>Description</b>	Display of current messages about operating status		
<b>Display values</b>	📖 Section 6 "Operating status messages"		
<b>P707</b>	<b>Software version</b>		
<b>Display range</b>	0.0 ... 9999.0		
<b>Arrays</b>	[-01] = Version	Version number (e.g.: V1.0)	
	[-02] = Revision	Revision number (e.g.: R1)	
	[-03] = Special version	Special version of hardware/software (e.g. 0.0). The value "0" means "Standard version".	
<b>Description</b>	Display of software version (firmware version) of device		
<b>P708</b>	<b>Digital input status.</b>		<b>RD</b>
<b>Display range</b>	0000 0000 0000 ... 0111 1111 1111 <small>(bin)</small>	0000 ... 07FF <small>(hex)</small>	
<b>Description</b>	Display of switching status of the digital inputs		
<b>Display values</b>	<b>Value (Bit)</b>	<b>Meaning</b>	
	0	Digital input 1	Switching status of digital input 1
	1	Digital input 2	Switching status of digital input 2
	2	Digital input 3	Switching status of digital input 3
	3	PTC input	PTC resistor input switching status
	4	Bus In Bit 0	Signal status Bus In Bit 0
	5	Bus In Bit 1	Signal status Bus In Bit 1
	6	Bus In Bit 2	Signal status Bus In Bit 2
	7	Bus In Bit 3	Signal status Bus In Bit 3
	8	Digital input 1 BUS	Switching status of Bus digital input 1
	9	Digital input 2 BUS	Switching status of Bus digital input 2
	10	STO input	Signal status STO input
<b>P709</b>	<b>Potentiometer status</b>		<b>RD</b>
<b>Display range</b>	0,0 ... 100,0 %		
<b>Arrays</b>	[-01] = DIP switch S1	Actual value in % of 3.6 A (SK 1xxE-FDS-151-...), or Actual value in % of 7.5 A (SK 1xxE-FDS-301-...)	
	[-02] = Potentiometer P1	Actual value in % of 25.6 s	
	[-03] = Potentiometer P2	Current value in % of 100 % start voltage	
	[-04] = Potentiometer P3	Current value in % of 25.6 s	
<b>Description</b>	Display of the set values of DIP switch <b>S1</b> or potentiometer <b>P1</b> ... <b>P3</b> , <i>relative to the particular end values of the scale</i> (in %)		

<b>P711</b>	<b>Digital output status</b>		<b>RD</b>
<b>Display range</b>	0000 0000 ... 0111 1111 (bin)	00 ... 7F (hex)	
<b>Description</b>	Display of switching status of the digital inputs		
<b>Display values</b>	<b>Value (Bit)</b>	<b>Meaning</b>	
	0	Digital output 1	Switching status of digital output 1
	1	Digital output 2	Switching status of digital output 2
	2	Mechanical b.	Switching status of mechanical brake output
	3	Bus / AS-i Out Bit0	Switching status of Bus Out Bit 1
	4	Bus / AS-i Out Bit1	Switching status of Bus Out Bit 2
	5	Bus / AS-i Out Bit2	Switching status of Bus digital input 1
	6	Bus / AS-i Out Bit3	Switching status of Bus digital input 2

<b>P716</b>	<b>Current frequency</b>		<b>RD</b>
<b>Display range</b>	- 70 ... + 70 Hz		
<b>Description</b>	Display of current output frequency		
<b>Note</b>	The value is calculated from the mains frequency and the selected direction of rotation when enabling takes place. In the switched-off condition (drive not enabled) a value of "Zero" is output.		

<b>P718</b>	<b>Mains frequency</b>		<b>RD</b>
<b>Display range</b>	- 70 ... + 70 Hz		
<b>Description</b>	Display of current mains frequency		

<b>P719</b>	<b>Current current</b>		<b>RD</b>
<b>Display range</b>	0.0 ... 999.9 A		
<b>Description</b>	Display of current output current		

<b>P720</b>	<b>Effective current</b>		<b>RD</b>
<b>Display range</b>	-999.9 ... + 999.9 A		
<b>Description</b>	Display of current measured effective current		
<b>Display values</b>	<b>Value</b>	<b>Meaning</b>	
	-999.9 ... - 0.1	Generator current	
	0 ... + 999.9	Motor current	

<b>P721</b>	<b>Reactive current</b>		<b>RD</b>
<b>Display range</b>	-999.9 ... + 999.9 A		
<b>Description</b>	Display of current measured reactive current		

<b>P722</b>	<b>Current voltage</b>		<b>RD</b>
<b>Display range</b>	0 ... 500 V		
<b>Description</b>	Display of current AC voltage present at the output terminals		

<b>P723</b>	<b>Voltage -d</b>	<b>RD</b>	<b>S</b>
<b>Display range</b>	-500 ... + 500 V		
<b>Description</b>	Display of current voltage component U <sub>d</sub>		
<b>Note</b>	The value is typically "0".		
<b>P724</b>	<b>Voltage -q</b>	<b>RD</b>	<b>S</b>
<b>Display range</b>	-500 ... + 500 V		
<b>Description</b>	Display of current voltage component U <sub>q</sub>		
<b>Note</b>	The value is typically the same as that of parameter <b>P722</b> .		
<b>P725</b>	<b>Current cos phi</b>	<b>RD</b>	
<b>Display range</b>	0.00 ... 1.00		
<b>Description</b>	Display of current calculated cos phi value		
<b>P726</b>	<b>Apparent power</b>	<b>RD</b>	
<b>Display range</b>	0.00 ... 99.99 kVA		
<b>Description</b>	Display of current calculated apparent power		
<b>Note</b>	The calculation is based on motor data ( <b>P203</b> ).		
<b>P727</b>	<b>Mechanical power</b>	<b>RD</b>	
<b>Display range</b>	-99.99 ... + 99.99 kW		
<b>Description</b>	Display of current calculated effective power at motor		
<b>P728</b>	<b>Present Mains voltage</b>	<b>RD</b>	
<b>Display range</b>	0 ... 1000 V		
<b>Description</b>	Display of current supply voltage present at the input terminals		
<b>P732</b>	<b>Phase U current</b>	<b>RD</b>	
<b>Display range</b>	0.0 ... 999.9 A		
<b>Description</b>	Display of currently measured voltage of phase U		
<b>Note</b>	Because of the measuring procedure, the value of <b>P719</b> can deviate in spite of symmetrical output currents.		
<b>P733</b>	<b>Phase V current</b>	<b>RD</b>	
<b>Display range</b>	0.0 ... 999.9 A		
<b>Description</b>	Display of currently measured voltage of phase V		
<b>Note</b>	Because of the measuring procedure, the value of <b>P719</b> can deviate in spite of symmetrical output currents.		
<b>P734</b>	<b>Phase W current</b>	<b>RD</b>	
<b>Display range</b>	0.0 ... 999.9 A		
<b>Description</b>	Display of currently measured voltage of phase W		
<b>Note</b>	Because of the measuring procedure, the value of <b>P719</b> can deviate in spite of symmetrical output currents.		

P740	Bus In process data		RD	S
<b>Display range</b>	0000 ... FFFF (hex)	-32768 ... + 32767 (dec)		
<b>Arrays</b>	[-01] = Control word [-02] = ... [-04] [-05] = Parameter data In 1 [-06] = Parameter data In 2 [-07] = Parameter data In 3 [-08] = Parameter data In 4 [-09] = Parameter data In 5	not used  <b>Data during parameter transfer:</b> Order label (AK), Parameter number (PNU), Index (IND), Parameter value (PWE1 / PWE2)		
<b>Description</b>	Display of process and parameter data that is directed at the device and transmitted via the bus.			

P741	Bus Out process data		RD	S
<b>Display range</b>	0000 ... FFFF (hex)	-32768 ... + 32767 (dec)		
<b>Arrays</b>	[-01] = Bus status word [-02] = Bus - Actual value 1 [-03] = Bus - Actual value 2 [-04] = Bus - Actual value 3 [-05] = Parameter data Out 1 [-06] = Parameter data Out 2 [-07] = Parameter data Out 3 [-08] = Parameter data Out 4 [-09] = Parameter data Out 5	= Status word Error number in high byte, warning number in low byte Current current is relation to nominal current of device Current effective current is relation to nominal current of device  <b>Data during parameter transfer.</b>		
<b>Description</b>	Display of process and parameter data that is transmitted by the device via the bus.			

P743	Device type	RD	
<b>Display range</b>	0.25 ... 11.00 kW		
<b>Description</b>	Display of nominal device output (e.g.: 3.00 = device with 3.0 kW nominal output)		

P744	Configuration		RD	
<b>Display range</b>	0 ... 11			
<b>Description</b>	Displays the configuration of the device			
<b>Display values</b>	<b>Value</b>	<b>Meaning</b>		
	0-4	<i>reserved</i>		
	5	SK 155E (AS-i)	Motor starters with soft-start function + integrated AS interface	
	6	<i>reserved</i>		
	7	SK 175E (AS-i)	Motor starter with soft start and reversing function + integrated AS interface	
	8	<i>reserved</i>		
	9	SK 155E (Profibus)	Motor starters with soft-start function + integrated PROFIBUS DP interface	
	10	<i>reserved</i>		
	11	SK 175E (Profibus)	Motor starter with soft start and reversing function + integrated PROFIBUS DP interface	

<b>P749</b>	<b>Status of DIP switch</b>			<b>RD</b>
<b>Display range</b>	0000 0000 ... 1111 1111 (bin)	00 ... FF (hex)	0 ... 255 (dec)	
<b>Description</b>	Display of switch status of DIP switch ( <b>S1</b> , <b>S2</b> ).			
<b>Display values</b>	<b>Value (Bit)</b>	<b>Meaning</b>		
	0	DIP switch 1	Switching status of DIP switch element 1	
	1	DIP switch 2	Switching status of DIP switch element 2	
	2	DIP switch 3	Switching status of DIP switch element 3	
	3	DIP switch 4	Switching status of DIP switch element 4	
<b>P752</b>	<b>Changeover relay error</b>			<b>RD</b>
<b>Display range</b>	0 ... 10			
<b>Description</b>	Display of the errors caused by a changeover relay ( <b>E18.3</b> ). The changeover relay performs the change of direction of the motor in reversing mode.			
<b>Note</b>	After the 10th error occurs the device is no longer operational and must be sent for repair. This parameter is only available for devices with reversing function (SK 175E-FDS).			
<b>P753</b>	<b>Bypass relay error</b>			<b>RD</b>
<b>Display range</b>	0 ... 10			
<b>Description</b>	Display of the errors caused by a bypass relay ( <b>E18.4</b> ). The bypass relay bypasses the thyristor module after completion of the acceleration phase.			
<b>Note</b>	After the 10th error occurs the device is no longer operational and must be sent for repair. The parameter is only available for devices with soft start function (SK 155E-FDS, SK 175E-FDS).			
<b>P762</b>	<b>Phase U voltage</b>			<b>RD</b>
<b>Display range</b>	0 ... 500 V			
<b>Description</b>	Display of current voltage of phase U			
<b>Note</b>	The value of <b>P722</b> can differ because of the measuring procedure, in spite of having symmetrical output voltages.			
<b>P763</b>	<b>Phase V voltage</b>			<b>RD</b>
<b>Display range</b>	0 ... 500 V			
<b>Description</b>	Display of current voltage of phase V			
<b>Note</b>	The value of <b>P722</b> can differ because of the measuring procedure, in spite of having symmetrical output voltages.			
<b>P764</b>	<b>Phase W voltage</b>			<b>RD</b>
<b>Display range</b>	0 ... 500 V			
<b>Description</b>	Display of current voltage of phase W			
<b>Note</b>	Because of the measuring procedure, the value of <b>P72</b> can deviate in spite of symmetrical output voltages.			
<b>P780</b>	<b>Device ID</b>			
<b>Display range</b>	0 ... 9 and A ... Z (char)			
<b>Arrays</b>	[-01] = ... [-14]			
<b>Description</b>	Display of the serial number (14-digit) of the device.			
<b>Note</b>	<ul style="list-style-type: none"> <li>• Display via NORDCON: as a contiguous serial number of the device</li> <li>• Display via bus: ASCII code (decimal). Each array must be read out separately.</li> </ul>			

## 6 Operating status messages

The device and technology units generate appropriate messages if they deviate from their normal operating status. There is a differentiation between warning and error messages. If the device is in the status "Start disabled", the reason for this can also be displayed.

The messages generated for the device are displayed in the corresponding array of parameter (**P700**). The display of the messages for technology units is described in the respective additional instructions and data sheets for the modules concerned.

### Start disabled, "Not Ready" → (**P700 [-03]**)

If the device is in the status "Not Ready" or "Start Disabled", the reason for this is indicated in the third array element of parameter (**P700**).

Display is only possible with the NORD CON software or the ParameterBox.

### Warning messages → (**P700 [-02]**)

Warning messages are generated as soon as a defined limit is reached. However this does not cause the frequency inverter to switch off. These messages can be displayed via the array-element [-02] in parameter (**P700**) until either the reason for the warning is no longer present or the frequency inverter has gone into a fault state with an error message.

### Error messages → (**P700 [-01]**)

Errors cause the device to switch off, in order to prevent a device fault.

The following options are available to reset a fault (acknowledge):

- Switching the mains off and on again,
- By an appropriately programmed digital input (**P420**),
- By switching off the "enable" on the device (if no digital input is programmed for acknowledgement),
- By Bus acknowledgement

## 6.1 Display of messages

### LED indicators

The device status is indicated by an externally visible "FI status" LED ( Section 3 "Display, operation and options").

### SimpleBox Display

The SimpleBox displays an error with its number and the prefix "E". In addition, the present fault can be displayed in array element [-01] of parameter (**P700**). The last error messages are stored in parameter (**P701**). Further information about the frequency inverter status at the moment of the fault can be obtained from parameters (**P702**) to (**P706**) / (**P799**)

If the cause of the error is no longer present, the error display in the SimpleBox flashes and the error can be acknowledged with the Enter key.

In contrast, warning messages are prefixed with "C" ("**Cxxx**") and cannot be acknowledged. They disappear automatically when the reason for them is no longer present or the frequency inverter has switched to the "Error" state. Display of the message is suppressed if the warning appears during parameterisation.

The present warning message can be displayed in detail at any time in array element [-02] of parameter (**P700**).

The reason for an existing disabled switch on cannot be displayed with the SimpleBox.

### ParameterBox display

The ParameterBox displays the messages in plain text.

## 6.2 Diagnostic LEDs on device

The device generates operating status messages. These messages (warnings, errors, switching statuses, measurement data) can be displayed with parametrisation tools (📖 Section 3.2 "Control and parametrisation options ") (Parameter group **P7xx**).

To a limited extent, the messages are also indicated via the diagnostic and status LEDs.

### Diagnostic LEDs

LED			Status signal <sup>1)</sup>		Meaning
Name	Colour	Description			
DS	red/ green	Device status	Off		Device not ready for operation • no control voltage
			green on		Device is switched on (running)
			flashing green	0.5 Hz	Device ready for switching on
				4 Hz	Device is in switch-on block
			red/ green Alternating	4 Hz	Warning
				0.5 Hz	Device not ready for switching on • 24 V DC supply is present, but mains voltage is not
	flashing red	Error, flashing frequency corresponds to error number			
ASi	red/ green/ yellow	Status AS-i			Details (📖 Section 4.3.4.2)
BR	green	Status PBR			Details (📖 Section 4.4.3.2)

1) Signal status = specification of LED colour + flashing frequency (switch-on frequency per second), example "flashing red, 2 Hz" = red LED switches on and off 2 x per second

### 6.3 Messages

#### Error messages

Display in the SimpleBox / ControlBox		Fault Text in the ParameterBox	Cause • Remedy
Group	Details in P700 [-01] / P701		
E001	1.0	<b>Overtemp. Thyristor</b> <i>"Thyristor module overtemperature"</i>	Temperature monitoring of the thyristor module Temperature monitoring is performed on the basis of a calculation model. The error message is triggered if the results exceed the permissible temperature range. <ul style="list-style-type: none"> <li>• Check the ambient temperature</li> <li>• Reduce the motor load during the acceleration phase</li> <li>• Check the device for dirt</li> </ul>
E002	2.2	<b>Ext Resistor Temp</b> <i>"External braking resistor overtemperature"</i>	Temperature sensor (e.g. braking resistor) has been triggered. The digital input is "low". <ul style="list-style-type: none"> <li>• Check connection and temperature sensor.</li> </ul>
E003	3.0	<b>I<sup>2</sup>t overcurrent limit</b>	<ul style="list-style-type: none"> <li>• Continuous overload on the motor</li> </ul>
	3.3	<b>Thyristor overcurrent</b>	<ul style="list-style-type: none"> <li>• Continuous overload on the motor during acceleration phase</li> </ul>
E004	4.5	<b>Overcurrent / short circuit in the brake rectifier</b> <i>Overcurrent / short circuit in the brake rectifier</i>	<ul style="list-style-type: none"> <li>• Electromechanical brake defective</li> <li>• Electromechanical brake connected with impermissible electrical data → Check the connection data</li> </ul>
E005	5.1	<b>Mains overvoltage</b>	Mains voltage is too high <ul style="list-style-type: none"> <li>• See technical data (📖 Section 7)</li> </ul>
E006	6.1	<b>Mains undervoltage</b>	Mains voltage too low <ul style="list-style-type: none"> <li>• See technical data (📖 Section 7)</li> </ul>
E007	7.0	<b>Mains phase error</b>	Error at terminal connection side <ul style="list-style-type: none"> <li>• a network phase is not connected</li> <li>• network is non-symmetrical</li> </ul>
E016	16.0	<b>Motor phase error</b>	A motor phase is not connected. <ul style="list-style-type: none"> <li>• Check P539</li> <li>• Check motor connection</li> </ul>
	16.1	<b>Magnetisation current monitoring</b> <i>"Magnetisation current monitoring"</i>	Required exciting current not achieved at moment of switch-on. <ul style="list-style-type: none"> <li>• Check P539</li> <li>• Check motor connection</li> </ul>

E018	<b>18.0</b>	<b>Reserved</b>	
	<b>18.1</b>	<b>Reserved</b>	
	<b>18.2</b>	<b>Reserved</b>	
	<b>18.3</b>	<b>Changeover relay sticking</b>	<p>A relay which is relevant for implementation of the change of direction of the motor (reversing mode) is sticking or is defective.</p> <p>This error message can only be acknowledged by switching off the device. Each error which occurs is counted (<b>P752</b>). After the 10th error occurs the device is no longer operational and must be sent for repair.</p> <p>Only relevant for devices with reversing function (SK 175E-FDS).</p>
	<b>18.4</b>	<b>Bypass relay sticking</b>	<p>A relay which is relevant for bypassing the thyristor module (changeover from acceleration phase to normal motor operation) is sticking or is defective.</p> <p>This error message can only be acknowledged by switching off the device. Each error which occurs is counted (<b>P753</b>). After the 10th error occurs the device is no longer operational and must be sent for repair.</p> <p>Only relevant for devices with soft start function (SK 175E-FDS).</p>
E020	<b>20.0</b>	<b>Reserved</b>	
E021	<b>20.1</b>	<b>Watchdog</b>	
	<b>20.2</b>	<b>Stack overflow</b>	
	<b>20.3</b>	<b>Stack underflow</b>	
	<b>20.4</b>	<b>Undefined opcode</b>	
	<b>20.5</b>	<b>Protected Instruct.</b> <i>"Protected Instruction"</i>	
	<b>20.6</b>	<b>Illegal word access</b>	
	<b>20.7</b>	<b>Illegal Inst. Access</b> <i>"Illegal instruction access"</i>	<p>System error in program execution, triggered by EMC interference.</p> <ul style="list-style-type: none"> <li>• Observe wiring guidelines</li> <li>• Use additional external mains filter.</li> <li>• FI must be very well earthed.</li> </ul>
	<b>20.8</b>	<b>Program memory error</b> <i>"Program memory error"</i> (EEPROM error)	
	<b>20.9</b>	<b>Dual-ported RAM</b>	
	<b>21.0</b>	<b>NMI error</b> (Not used by hardware)	
	<b>21.1</b>	<b>PLL error</b>	
	<b>21.2</b>	<b>ADU error "Overrun"</b>	
	<b>21.3</b>	<b>PMI error "Access Error"</b>	
	<b>21.4</b>	<b>Userstack overflow</b>	

### Warning messages

Display in the SimpleBox / ControlBox		Warning Text in the ParameterBox	Cause • Remedy
Group	Details in P700 [-02]		
C002	2.0	<b>Overtemp. Motor PTC</b> "Overtemperature motor thermistor"	Warning from motor temperature sensor (triggering threshold reached) • Reduce motor load
C003	3.0	<b>I<sup>2</sup>t overcurrent limit</b>	Warning: I <sup>2</sup> t limit e.g. output current > nominal current of motor Reaching 1.3 times the nominal motor current for the duration of 60 s. • Continuous motor overload

### Switch-on block messages

Display in the SimpleBox / ControlBox		Reason: Text in the ParameterBox	Cause • Remedy
Group	Details in P700 [-03]		
I000	0.1	<b>Disable voltage from IO</b>	If the "disable voltage" function is parametrised, input (P420 / P480) is Low • "Set High" input • Check signal cable (broken cable)
	0.3	<b>Disable voltage from bus</b>	• Bus operation (P509): control word Bit 1 is "Low"
	0.5	<b>Enable on start</b>	Enable signal (control word, Dig I/O or Bus I/O) was already applied during the initialisation phase (after mains "ON", or control voltage "ON"). • Only issue enable signal after completion of initialisation (i.e. when the FI is ready) • Activation of "Automatic Start" (P428)  With 3-phase devices: One phase is missing or not connected.
I006	6.0	<b>Mains voltage error</b>	• Mains voltage failure

## 6.4 FAQ operational problems

Fault	Possible cause	Remedy
Device will not start (all LEDs off)	<ul style="list-style-type: none"> <li>No mains voltage or wrong mains voltage</li> <li>Devices without integrated mains unit (Option <b>-HVS</b>): No 24 V DC control voltage</li> </ul>	<ul style="list-style-type: none"> <li>Check connections and supply cables</li> <li>Check switches / fuses</li> </ul>
Device does not react to enabling	<ul style="list-style-type: none"> <li>Control elements not connected</li> <li>Right and left enable signals present simultaneously</li> <li>Enable signal present before device ready for operation (device expecting a 0 → 1 flank)</li> <li>Restart inhibit is active</li> <li>Blocking time for reversing is active</li> </ul>	<ul style="list-style-type: none"> <li>Reset enable</li> <li>Change over P428 if necessary: "0" = device expects a 0→1 flank for enable / "1" = device reacts to "Level" → Danger: Drive can start up independently!</li> <li>Check control connections</li> <li>Check P130</li> <li>Check DIP switch S2-DIP1</li> </ul>
Motor will not start in spite of enable being present	<ul style="list-style-type: none"> <li>Motor cables not connected</li> <li>Brake not ventilating</li> </ul>	<ul style="list-style-type: none"> <li>Check connections and supply cables</li> </ul>
Device switches off without error message when load increases (increased mechanical load / speed)	<ul style="list-style-type: none"> <li>Mains phase missing</li> </ul>	<ul style="list-style-type: none"> <li>Check connections and supply cables</li> <li>Check switches / fuses</li> </ul>
Motor rotating in wrong direction	<ul style="list-style-type: none"> <li>Motor cable: U-V-W interchanged</li> </ul>	<ul style="list-style-type: none"> <li>Motor connection: Switch 2 phases</li> <li>Alternatively: <ul style="list-style-type: none"> <li>– Swap parameter <b>P420</b> functions right / left enable</li> </ul> </li> </ul>

Table 6: FAQ operational problems

## 7 Technical data

### 7.1 General motor starter data

Function	Specification
Motor overload monitoring	150% for 9 s ... 170 s, depending on the switch-off class ( <b>P535</b> )
Motor starter efficiency	> 98 %
Insulation resistance	> 5 MΩ
Operating/ambient temperature	-25°C ... +50°C, depending on the operating mode (📖 Section 7.2.1)
Storage and transport temperature	-25°C ... +60/70°C
Long-term storage	(📖 Section 9.1)
Protection class	IP65
Max. installation altitude above sea level	<i>up to 1000 m</i> No power reduction <i>1000...2000 m:</i> 0.25%/100 m power reduction, overvoltage cat. 3 <i>2000...4000 m:</i> 0.25%/100 m power reduction, overvoltage cat. 2, external overvoltage protection required at mains input
Ambient conditions	<i>Transport (IEC 60721-3-2):</i> Mechanical: 2M2 <i>Operation (IEC 60721-3-3):</i> Mechanical: 3M6 Climatic: 3K3 (IP55)      3K3 (IP65)
Environmental protection	<i>EMC</i> (📖 Section 1.7) <i>RoHS</i> (📖 Section 1.7)
Protective measures against	Mains phase failure,      Motor magnetisation monitoring Motor phase failure
Motor temperature monitoring	I <sup>2</sup> t-Motor, PTC/bimetallic switch
Soft start (if available)	Phase section, 2-phase
Waiting period between two mains switch-on cycles	60 s for all devices in normal operating cycle
Interfaces	<i>Standard</i> RS485 (single slave) <i>Option</i> AS-i on board (📖 Section 4.3) PROFIBUS DP – on board (📖 Section 4.4)
Electrical isolation	Control terminals
Connection terminals, electrical connection	<i>Power unit</i> (📖 Section 2.3.2) <i>Control unit</i> (📖 Section 2.3.3)

## 7.2 Electrical data

The following tables contain the data which is relevant for UL.

Details of the UL/CSA approval conditions can be found in Section 1.7.1 "UL and CSA approval". Use of mains fuses which are faster than those stated is permissible.

### 7.2.1 Electrical data

Device type		SK 1x5E-FDS-...	-111-340	-301-340-				
Size			0	1				
Nominal motor power (4-pole standard motor)	400 V		1.1 kW	3.0 kW				
	480 V		1.5 hp	4 hp				
Mains voltage		<b>3 AC</b> 380 V – 20% ... 500 V + 10%, 47 ... 63 Hz						
Input current	rms		3.1 A	7.5 A				
	FLA		3.1 A	7.0 A				
Output voltage		<b>3 AC</b> 0 ... Mains voltage						
Output current	rms		3.1 A	7.5 A				
	FLA		3.1 A	7.0 A				
	LRA		21.7 A	49.0 A				
Maximum continuous power / maximum continuous current								
		S1-50°C	1.1 kW/3.1 A	3.0 kW/7.5 A				
			<b>General fuses (AC) (recommended)</b>					
Slow-blowing			7.5 ... 16 A <sup>1)</sup>	7.5 ... 16 A <sup>1)</sup>				
		Class)	<b>Fuses (AC) UL-approved<sup>3)</sup></b>					
			Isc <sup>2)</sup> [A]					
			5 000	10 000	65 000			
Fuse	RK5	x				30 A	30 A	
	CA, CC, CF, J, T, G			x		30 A	30 A	
CB <sup>4)</sup>	500 V		x			30 A	30 A	

1) Fuse size depends on size of connected motor, for group fuse: maximum fuse size: 30 A

2) Maximum permissible mains short circuit current. This may be reduced by the selected connection combination or maintenance switch.

3) Note the current limitation imposed by the power plug connector used (see 1.7.1 "UL and CSA approval")

4) "Inverse time trip type" according to UL 489

## **8 Additional information**

### **8.1 Electromagnetic compatibility (EMC)**

#### **8.1.1 General Provisions**

As of July 2007, all electrical equipment which has an intrinsic, independent function and which is sold as an individual unit for end users, must comply with Directive 2004/108/EEC (formerly Directive EEC/89/336). There are three different ways for manufacturers to indicate compliance with this directive:

*1. EU Declaration of Conformity*

This is a declaration from the manufacturer, stating that the requirements in the applicable European standards for the electrical environment of the equipment have been met. Only those standards which are published in the Official Journal of the European Community may be cited in the manufacturer's declaration.

*2. Technical documentation*

Technical documentation can be produced which describes the EMC characteristics of the device. This documentation must be authorised by one of the "Responsible bodies" named by the responsible European government. This makes it possible to use standards which are still in preparation.

*3. EU Type test certificate*

This method only applies to radio transmitter equipment.

The devices only have an intrinsic function when they are connected to other equipment (e.g. to a motor). The base units cannot therefore carry the CE mark that would confirm compliance with the EMC directive. Precise details are therefore given below about the EMC behaviour of this product, based on the proviso that it is installed according to the guidelines and instructions described in this documentation.

The manufacturer can certify that his equipment meets the requirements of the EMC directive in the relevant environment with regard to their EMC behaviour in power drives. The relevant limit values correspond to the basic standards EN 61000-6-2 and EN 61000-6-4 for interference immunity and interference emissions.

### 8.1.2 EMC evaluation - EN 55011-1 (environmental standard)

The limits are defined in dependence on the basic environment in which the product is operated in this standard. A distinction is made between 2 environments, whereby the **1st environment** describes the non-industrial **living and business area** without its own high-voltage or medium-voltage distribution transformers. The **2nd environment**, on the other hand, defines **industrial areas** which are not connected to the public low-voltage network, but have their own high-voltage or medium-voltage distribution transformers. The limits are subdivided into **classes A and B**.

Limit class in accordance with EN 55011	B	A
Operation permissible in		
1. Environment (living environment)	X	-
2. Environment (industrial environment)	X	X <sup>1)</sup>
Note required in accordance with EN-61800-3	-	2)
Sales channel	Generally available	Limited availability
EMC situation	No requirements	Installation and start-up by EMC expert
1) Device used neither as a plug-in device nor in moving equipment		
2) "The drive system is not intended for use in a public low-voltage network that feeds residential areas".		

**Table 7: EMC - Limit class in accordance with EN 55011**

### 8.1.3 EMC of device

#### NOTICE

##### EMC interference to the environment

This device produces high-frequency interference, which may make additional suppression measures necessary in domestic environments (☐ 8.1 "Electromagnetic compatibility (EMC)").

The device is exclusively intended for commercial use. It is therefore not subject to the requirements of the standard EN 61000-3-2 for radiation of harmonics.

The limit value classes are only achieved if

- the wiring is EMC-compliant
- the length of shielded motor cable does not exceed the permissible limits



If a shielded motor cable is used, the shield of the motor cable must be connected to the motor.

Device version Max. motor cable length, shielded	Conducted emissions 150 kHz - 30 MHz	
	Class A	Class B
Standard configuration for operation on TN/TT networks (active integrated mains filter)	20 m	-

EMC overview of standards that are used in accordance with EN 60947-4-2 as checking and measuring procedures:		
<i>Interference emission</i>		
Cable-related emission (interference voltage)	EN 55011	A
		-
Radiated emission (interference field strength)	EN 55011	A
		-
<i>Interference immunity EN 61000-6-1, EN 61000-6-2</i>		
ESD, discharge of static electricity	EN 61000-4-2	6 kV (CD), 8 kV (AD)
EMF, high frequency electro-magnetic fields	EN 61000-4-3	10 V/m; 80 – 1000 MHz
Burst on control cables	EN 61000-4-4	1 kV
Burst on mains and motor cables	EN 61000-4-4	2 kV
Surge (phase-phase / phase-ground)	EN 61000-4-5	1 kV / 2 kV
Cable-led interference due to high frequency fields	EN 61000-4-6	10 V, 0.15 – 80 MHz
Voltage fluctuations and drops	EN 61000-2-1	+10 %, -15 %; 90 %
Voltage asymmetries and frequency changes	EN 61000-2-4	3 %; 2 %

Table 8: Overview according to product standard EN 60947-4-2

## 8.1.4 EU Declaration of Conformity

 <h1 style="margin: 0;">GETRIEBEBAU NORD</h1> <p style="margin: 0;">Member of the NORD DRIVESYSTEMS Group</p>																		
<p><b>Getriebebau NORD GmbH &amp; Co. KG</b>          Getriebebau-Nord-Str. 1 . 22941 Bargteheide, Germany . Fon +49(0)4532 289 - 0 . Fax +49(0)4532 289 - 2253 . info@nord.com <span style="float: right;">C310801_1121</span></p>																		
<h2 style="margin: 0;">EU Declaration of Conformity</h2> <p style="margin: 0; font-size: small;">In the meaning of the directive 2014/35/EU Annex IV and 2014/30/EU Annex II, 2011/65/EU Annex VI</p>																		
<p>Getriebebau NORD GmbH &amp; Co. KG as manufacturer in sole responsibility hereby declares, <span style="float: right;">Page 1 of 1</span>          that the electronic motor starter from the product series NORDAC LINK</p> <ul style="list-style-type: none"> <li>• <b>SK 155E-FDS-xxx-340-A-.. , SK 175E-FDS-xxx-340-A-..</b>              (xxx= 151, 301, 751)</li> </ul> <p>and the further options/accessories:  <b>SK CU4-... , SK TU4-... , SK TIE4-... , SK PAR-3. , SK CSX-3. , SK TIE5-BT-STICK</b></p> <p>comply with the following regulations:</p> <table style="width: 100%; border: none;"> <tr> <td style="width: 30%;"><b>Low Voltage Directive</b></td> <td style="width: 30%;"><b>2014/35/EU</b></td> <td style="width: 40%;">OJ. L 96 of 29.3.2014, p. 357–374</td> </tr> <tr> <td><b>EMC Directive</b></td> <td><b>2014/30/EU</b></td> <td>OJ. L 96 of 29.3.2014, p. 79–106</td> </tr> <tr> <td><b>RoHS Directive</b></td> <td><b>2011/65/EU</b></td> <td>OJ. L 174 of 1.7.2011, p. 88–11</td> </tr> <tr> <td><b>Delegated Directive (EU)</b></td> <td><b>2015/863</b></td> <td>OJ. L 137 of 4.6.2015, p. 10–12</td> </tr> </table> <p><b>Applied standards:</b></p> <table style="width: 100%; border: none;"> <tr> <td style="width: 33%;">EN 60947-1:2007+A1:2011+A2:2014+AC:2015</td> <td style="width: 33%;">EN 60947-4-2:2012</td> <td style="width: 33%;">EN 63000:2018</td> </tr> <tr> <td>EN 60529:1991+A1:2000+A2:2013+AC:2016</td> <td></td> <td></td> </tr> </table> <p>It is necessary to notice the data in the operating manual to meet the regulations of the EMC-Directive.          Specially take care about correct EMC installation and cabling, differences in the field of applications and if necessary original accessories.</p> <p>First marking was carried out in 2016.</p> <p><b>Bargteheide, 17.03.2021</b></p> <div style="display: flex; justify-content: space-around; margin-top: 20px;"> <div style="text-align: center;">  <p>U. Küchenmeister Managing Director</p> </div> <div style="text-align: center;">  <p>pp F. Wiedemann Head of Inverter Division</p> </div> </div>	<b>Low Voltage Directive</b>	<b>2014/35/EU</b>	OJ. L 96 of 29.3.2014, p. 357–374	<b>EMC Directive</b>	<b>2014/30/EU</b>	OJ. L 96 of 29.3.2014, p. 79–106	<b>RoHS Directive</b>	<b>2011/65/EU</b>	OJ. L 174 of 1.7.2011, p. 88–11	<b>Delegated Directive (EU)</b>	<b>2015/863</b>	OJ. L 137 of 4.6.2015, p. 10–12	EN 60947-1:2007+A1:2011+A2:2014+AC:2015	EN 60947-4-2:2012	EN 63000:2018	EN 60529:1991+A1:2000+A2:2013+AC:2016		
<b>Low Voltage Directive</b>	<b>2014/35/EU</b>	OJ. L 96 of 29.3.2014, p. 357–374																
<b>EMC Directive</b>	<b>2014/30/EU</b>	OJ. L 96 of 29.3.2014, p. 79–106																
<b>RoHS Directive</b>	<b>2011/65/EU</b>	OJ. L 174 of 1.7.2011, p. 88–11																
<b>Delegated Directive (EU)</b>	<b>2015/863</b>	OJ. L 137 of 4.6.2015, p. 10–12																
EN 60947-1:2007+A1:2011+A2:2014+AC:2015	EN 60947-4-2:2012	EN 63000:2018																
EN 60529:1991+A1:2000+A2:2013+AC:2016																		

## 8.2 Operation on the FI circuit breaker

Leakage current of  $\leq 20$  mA is expected during operation of the motor starter. It is suitable for operation on the FI circuit breakers for the protection of persons.

## 8.3 Trigger classes (I<sup>2</sup>t)

The devices support the following trigger classes according to product standard IEC 60947-4-2:

- 5
- 10A
- 10 (only for motors with rated current  $\leq 4.0$  A)

The I<sup>2</sup>t-trigger classes also take into account the loads which occur under normal operation (less than 110 %). Because of this, the switch-off times differentiate between a motor which has been in operation for some time ("warm") motor and a "cold" motor which has just been started.

In addition, the trigger characteristic curves are subject to tolerances due to the relatively large measurement range.

The FI switches off immediately above an output current of 56 A. If the output current exceeds 9x the value of the rated motor current, switch-off is additionally accelerated (kink in the characteristic curves).

**This results in the following characteristic curves:**

### Outline conditions

- Typical for ambient temperature 20°C,
- Tolerance range, incl. temperature influences,
- Immediate triggering for  $I > 56$  A,
- Class 10 only for  $I_{nenn} \leq 4$  A

### Legend

- A: Response time
- B: Overcurrent factor  $I/I_{nenn}$  ( $I_{nenn}$ = parameterised rated current)

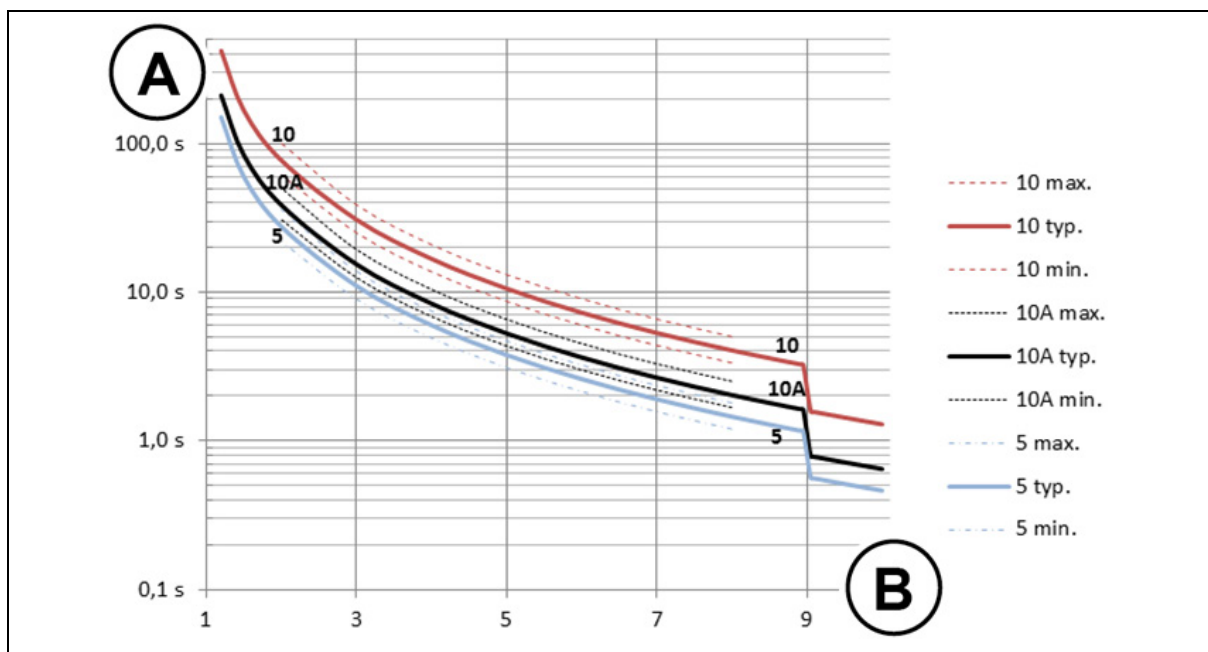

Figure 1: Trigger class curves

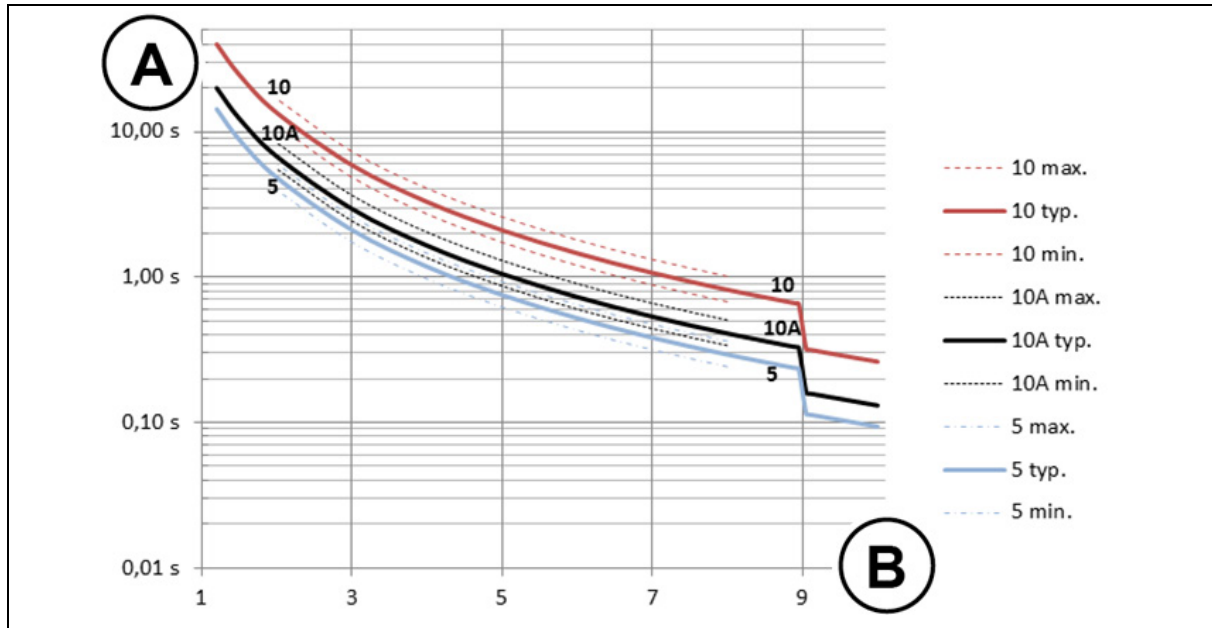

Figure 2: Trigger times for warm operating state (with previous:  $I = \text{continuous } I_{\text{enn}}$ )

## 8.4 Switch-on cycle

Depending on the version of the FI, various internal relays are used in the power circuit. Because of this, a switch-on block is integrated into the FI to protect the relays against overload during long acceleration phases and large motor currents.

The switch-on block is triggered by a timer, which starts immediately after the frequency inverter is switched on (enabled). The timer setting depends on the rated current of the motor and the acceleration time.

The maximum blocking time between two switch-on procedures is 1 second.

### 8.5 Connection accessories

The material for establishing the electrical connection is not included in the scope of delivery of the frequency inverter. However, it can be obtained from NORD or from other commercial sources.

#### 8.5.1 Power connections - mating connectors

Parts lists for some of the mating connectors of the installed plug connectors (power connections, (📖 Section 2.2.1.1 "Connection level")) are listed below.

*Installed plug connector type:*

**HARTING Q4/2+ (socket)**

Recommended products for mating connectors to the installed plug connector system

#### Hybrid plug connector HAN Q4/2 (pin)

Number	Designation	Manufacturer	Information
1 x	Sleeve housing, HAN-Compact	Harting	Straight cable outlet, M25 (19 12 008 0429 )
1 x	Contact insert HAN Q4/2 (pin)	Harting	(09 12 006 3041)
4 x	Crimp contact Pin 4mm <sup>2</sup>	Harting	(09 32 000 6107)
2 x	Crimp contact Pin 0.75mm <sup>2</sup>	Harting	(09 15 000 6105)
1 x	HAN-Compact Half cable gland	Harting	M25 – 14...17mm (19 12 000 5158)

*Installed plug connector type:*

**HARTING Q4/2+ (plug connector)**

Recommended products for mating connectors to the installed plug connector system

#### Hybrid plug connector HAN Q4/2 (socket)

Number	Designation	Manufacturer	Information
1 x	Sleeve housing, HAN-Compact	Harting	Straight cable outlet, M25 (19 12 008 0429)
1 x	Contact insert HAN Q4/2 (socket)	Harting	(09 12 006 3141)
4 x	Crimp contact socket 4mm <sup>2</sup>	Harting	(09 32 000 6207)
2 x	Crimp contact socket 0.75mm <sup>2</sup>	Harting	(09 15 000 6205)
1 x	HAN-Compact Half cable gland	Harting	M25 – 14...17mm (19 12 000 5158)

*Installed plug connector type:*

**HARTING Q8/0+ (socket)**

Recommended products for mating connectors to the installed plug connector system

#### Hybrid plug connector HAN Q8/0 (pin)

Quantity	Designation	Manufacturer	Information
1 x	Sleeve housing, HAN-Compact	Harting	Straight cable outlet, M25 (19 12 008 0429 )
1 x	Contact insert HAN Q8/0 (pin insert)	Harting	(09 12 008 3001)
8 x	Crimp contact socket 1.5mm <sup>2</sup>	Harting	(09 33 000 6104)
1 x	HAN-Compact half cable gland	Harting	M25 – 14...17mm (19 12 000 5158)

### 8.5.2 M12 Y distributor

To create complex supply or communication lines we recommend the use of Y distributors. These are mounted directly on the relevant M12 plug connector of the field distributor and enable direct connection to the particular line.

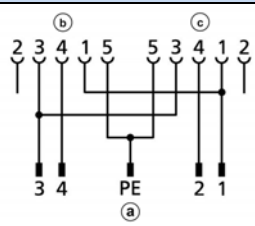
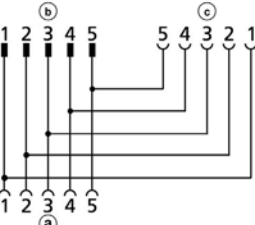
Designation	Material number	connection	Option slot	Contact diagram
SK TIE4-M12-INI-YFF	275274525	Initiator	M1, M3, M5, M7	
SK TIE4-M12-POW-YMF	275274526	24 V DC	M8	

Connection	Meaning
(a)	Inverter side
(b), (c)	Supply cable (as input or output)

### 8.5.3 Motor cable

Pre-assembled cables for the motor connection are available ([www.nord.com](http://www.nord.com)).

Designation	UL	Plug connector		Document
		FI side	Motor side	
SK CE-HQ8-K-MA-OE20-M4-xxUL	x	Pin, 8-pole	Open ends, M20 <sup>1)</sup>	<a href="#">TI 275274211-212</a>
SK CE-HQ8-K-MA-OE25-M4-xxUL	x	Pin, 8-pole	Open ends, M25 <sup>1)</sup>	<a href="#">TI 275274216-217</a>
SK CE-HQ8-K-MA-OE32-M4-xxUL	x	Pin, 8-pole	Open ends, M32 <sup>1)</sup>	<a href="#">TI 275274226-227</a>
SK CE-HQ8-K-MA-OE32-M5-xxUL	x	Pin, 8-pole	Open ends, M32 <sup>1)</sup>	<a href="#">TI 275274231-232</a>
SK CE-HQ8-K-MA-OE32-M6-xxUL	x	Pin, 8-pole	Open ends, M32 <sup>1)</sup>	<a href="#">TI 275274236-237</a>
SK CE-HQ8-K-MA-OE20-M4-xxM	-	Pin, 8-pole	Open ends, M20 <sup>1)</sup>	<a href="#">TI 275274800-803</a>
SK CE-HQ8-K-MA-OE25-M4-xxM	-	Pin, 8-pole	Open ends, M25 <sup>1)</sup>	<a href="#">TI 275274805-808</a>
SK CE-HQ8-K-MA-H10E-M1B-xxM	-	Pin, 8-pole	Socket, 8-pole	<a href="#">TI 275274810-813</a>
SK CE-HQ8-K-MA-OE32-M4-xxM	-	Pin, 8-pole	Open ends, M32 <sup>1)</sup>	<a href="#">TI 275274825-828</a>
SK CE-HQ8-K-MA-OE32-M5-xxM	-	Pin, 8-pole	Open ends, M32 <sup>1)</sup>	<a href="#">TI 275274830-833</a>
SK CE-HQ8-K-MA-OE32-M6-xxM	-	Pin, 8-pole	Open ends, M32 <sup>1)</sup>	<a href="#">TI 275274835-838</a>

1) EMC cable glands

### 8.5.4 Low voltage cable

Pre-assembled cables for the mains connection are available ([www.nord.com](http://www.nord.com)).

Designation	UL	Plug connector		Document
		FI side	Low voltage side	
SK CE-HQ4-K-LE-OE-xxUL	x	Socket, 6-pole	Open ends	<a href="#">TI 275274241-242</a>
SK CE-HQ42-K-LE-OE-xxUL	x	Socket, 6-pole	Open ends <sup>1)</sup>	<a href="#">TI 275274246-247</a>
SK CE-HQ4-K-LE-OE-xxM	-	Socket, 6-pole	Open ends	<a href="#">TI 275274840-843</a>
SK CE-HQ42-K-LE-OE-xxM	-	Socket, 6-pole	Open ends <sup>1)</sup>	<a href="#">TI 275274845-848</a>

1) Incl. 24 V DC cable

### 8.5.5 Daisy chain cable

Pre-assembled cables are available to loop the low voltage connection from one device to the next ([www.nord.com](http://www.nord.com)).

Designation	UL	Plug connector		Document
		FI side (Out)	FI side (In)	
SK CE-HQ4-K-LA-HQ4-xxUL	x	Pin, 6-pole	Socket, 6-pole	<a href="#">TI 275274251-252</a>
SK CE-HQ42-K-LA-HQ42-xxUL	x	Pin, 6-pole	Socket, 6-pole <sup>1)</sup>	<a href="#">TI 275274256-257</a>
SK CE-HQ4-K-LA-HQ4-xxM	-	Pin, 6-pole	Socket, 6-pole	<a href="#">TI 275274850-853</a>
SK CE-HQ42-K-LA-HQ42-xxM	-	Pin, 6-pole	Socket, 6-pole <sup>1)</sup>	<a href="#">TI 275274855-858</a>

1) Incl. 24 V DC cable

## 9 Maintenance and servicing information

### 9.1 Maintenance Instructions

NORD motor starts are *maintenance free* during proper operation ( Section 7 "Technical data").

#### **Long-term storage**

The device must be connected to the 24 V DC power supply at regular intervals.

If this is not done, there is a danger that the device may be destroyed.

If a device is going to be stored for longer than one year, it must be connected for 30 minutes via its 24 V DC supply only prior to making the normal mains connection.

### 9.2 Service notes

For service/repair cases please contact your NORD Service contact person. You will find your contact person listed on your order confirmation. Additionally you will find further possible contact persons using the following link: <https://www.nord.com/en/global/locatortool.jsp>.

When contacting our technical support please have the following information available:

- Device type (name plate/display)
- Serial number (name plate)
- Software version (parameter P707)
- Information regarding accessories and options used

If you would like to send the device in for repair please proceed as follows:

- Remove all non-original parts from the device.

NORD accepts no liability for any attached parts such as power cables, switches or external displays.

- Back up the parameter settings before sending in the device.
- State the reason for returning the component/device.
  - You can obtain a return note from our web site ([Link](#)) or from our technical support.
  - In order to rule out the possibility that the cause of a device fault is due to an optional module, the connected optional modules should also be returned in case of a fault.
- Specify a contact person for possible queries.



### Information

#### Factory settings of parameters

Unless otherwise agreed, the device is reset to the factory settings after inspection or repair.

---

The manual and additional information can be found on the Internet under [www.nord.com](http://www.nord.com).

### 9.3 Abbreviations

<b>AS-i (AS1)</b>	AS Interface	<b>GND</b>	Ground reference potential
<b>ASi (LED)</b>	Status LED - AS interface	<b>I/O</b>	In / Out (Input / Output)
<b>ASM</b>	Asynchronous machine, asynchronous motor	<b>LED</b>	Light-emitting diode
<b>AUX</b>	Auxiliary (voltage)	<b>LPS</b>	List of projected slaves (AS-I)
<b>BDI</b>	Bus digital input	<b>PBR</b>	PROFIBUS
<b>BR + / BR -</b>	Contacts for connecting a brake	<b>PDO</b>	Process data object (PROFIBUS)
<b>BR (LED)</b>	Status LED - PROFIBUS	<b>PE</b>	Protective earth
<b>DI (DIN)</b>	Digital input	<b>PELV</b>	Safety low voltage
<b>DS (LED)</b>	Status LED - device status	<b>PNU</b>	Parameter number (PROFIBUS)
<b>DO (DOUT)</b>	Digital output	<b>S</b>	Supervisor Parameter, P003
<b>I / O</b>	Input / Output	<b>SW</b>	Software version, P707
<b>EMC</b>	Electromagnetic compatibility	<b>TI</b>	Technical information / Data sheet (Data sheet for NORD accessories)
<b>FDS</b>	Field distributor( <b>F</b> ield <b>D</b> istribution <b>S</b> ystem)		
<b>FI (switch)</b>	Leakage current circuit breaker		

## Key word index

### A

Acceleration time (P102) .....	76
Accessories .....	107
Daisy chain cable .....	109
Mains cable .....	109
Motor cable .....	108
Y distributor .....	108
Apparent power (P726) .....	90
AS-Interface .....	58
Automatic starting (P428) .....	82

### B

Boost voltage (P215) .....	78
Brake reaction time (P107) .....	76
Brake release time (P114) .....	77
Bus status via PLC (P353) .....	79
Bypass relay error (P753) .....	92

### C

CE mark .....	101
Changeover relay error (P752) .....	92
Characteristics .....	11
Check input voltage (P538) .....	85
Configuration level (P744) .....	91
Connection cables	
Daisy chain .....	109
Low voltage .....	109
Motor .....	108
Connection material .....	107
Control options .....	47, 49, 71, 94
Current cos phi (P725) .....	90
Current current (P719) .....	89
Current frequency (P716) .....	89
Current limit (P536) .....	84
Current operating status (P700) .....	88
Current voltage (P722) .....	89

### D

Daisy chain cable .....	109
Device id (P780) .....	92

Device type (P743) .....	91
Digital inputs (P420) .....	81
Digital out function (P434) .....	83
Digital output status (P711) .....	89
DIP switch .....	55
Display .....	47, 93

### E

Effective current (P720) .....	89
Electrical data .....	20, 21, 100
Electromechanical brake .....	42
EMC Directive .....	40
Emerg. stop Error (P427) .....	82
Emission of interference .....	103
EN 61000 .....	103
Error in the event of overtemp. (P580) .....	87
Error messages .....	93, 94
EU Declaration of Conformity .....	101

### F

Factory setting (P523) .....	84
Factory settings .....	50
FAQ	
Operational problems .....	98
Faults .....	93, 94
FI circuit breaker .....	105
Flash copy order (P550) .....	85
Funct. input function (P400) .....	80
Function DIP switch (P499) .....	83

### I

I <sup>2</sup> t limit .....	95
i <sup>2</sup> t motor (P535) .....	84
I <sup>2</sup> t trigger characteristic curve .....	105
Immunity from interference .....	103
Installation altitude .....	99
Internet .....	111
IP protection class .....	26
IT network .....	41

<b>L</b>		Process data Bus In (P740).....	91
Leakage current.....	105	Process data Bus Out (P741).....	91
LEDs .....	93, 94	PROFIBUS DP.....	67
Locking time (P570).....	86	<b>R</b>	
<b>M</b>		Rated motor current (P203).....	78
Mains cable .....	109	Reactive current (P271).....	89
Mains frequency (P718).....	89	Run-down time (P103).....	76
Mains voltage error.....	97	<b>S</b>	
Maintenance .....	110	Selection display (P001).....	75
Manual brake release (P582).....	87	Software version (P707).....	88
Mechanical power (P727).....	90	Start voltage (P210).....	78
Menu group .....	72	Status of digital in. (P708).....	88
Messages .....	93, 94	Status of DIP switches (P749).....	92
Motor cable .....	108	Storage .....	110
<b>O</b>		Supervisor code (P003).....	75
Operating status .....	93, 94	Switch-off mode (P108).....	77
Operation.....	47, 93	Switch-on block.....	106
Output monitoring (P539).....	85	Switch-on cycle.....	106
Overcurrent.....	95	Switch-on cycles .....	99
<b>P</b>		<b>T</b>	
Parameter source (P130).....	77	Technical data.....	41, 77, 99, 110
Parametrisation options.....	47, 49, 71, 94	Technical Data	
Phase control mode (P131).....	78	Motor starters .....	41, 99
Phase sequence detection (P581).....	87	Time boost (P216).....	78
Phase U current (P732).....	90	Total currents .....	43
Phase U voltage (P762).....	92	Trigger classes.....	105
Phase V current (P733).....	90	Type code .....	23
Phase V voltage (P673).....	92	<b>U</b>	
Phase W current (P734).....	90	UL/CSA Approval.....	100
Phase W voltage (P764).....	92	<b>V</b>	
PLC display value (P360).....	79	Voltage –d (P723).....	90
PLC functionality (P350).....	79	Voltage –q (P724).....	90
PLC Integer setpoint (P355).....	79	<b>W</b>	
PLC Long setpoint (P356).....	79	Warning messages .....	97
PLC setpoint selection (P351).....	79	Warnings .....	93, 94, 97
PLC setpoints (P553).....	86	Wiring guidelines.....	39
PLC Status (P370).....	80	<b>Y</b>	
Potentiometer status (P709).....	88	Y distributor.....	108
Present Mains voltage (P728).....	90		



Headquarters  
Getriebebau NORD GmbH & Co. KG  
Getriebebau-Nord-Str. 1  
22941 Bargteheide, Deutschland  
T: +49 45 32 / 289 0  
F: +49 45 32 / 289 22 53  
info@nord.com